



TEXAS SOUTHMOST COLLEGE DISTRICT

THE UNIVERSITY OF TEXAS AT BROWNSVILLE and TEXAS SOUTHMOST COLLEGE

80 Fort Brown • Brownsville, Texas 78520 • (956) 882-3879 • Fax: (956) 882-8811 • <http://blue.utb.edu/vppa>

ACCEPTED FOR FILING
CAMERON COUNTY

2008 OCT 27 P 4:19

JOE S. RIVERA
COUNTY CLERK

Board of Trustees

David G. Oliveira

Chair

Eduardo A. Campirano

Vice Chair

Roberto Robles, M.D.

Secretary

Adela G. Garza

Chester Gonzalez

Rosemary Breedlove

René Torres

UTB/TSC President

Juliet V. García, Ph.D

Official Notice of the

**Texas Southmost College District
Regular Meeting**

**for
October 30, 2008**

Posted

October 27, 2008

AGENDA

The Board of Trustees of the Texas Southmost College District will convene **Thursday, October 30, 2008 at 4:30 p.m.** in the Gorgas Board Room of Texas Southmost College, 80 Fort Brown, Brownsville, Texas 78520.

Call to Order

1 Announcements

Certificate of Achievement for
Excellence in Financial Reporting

Cavalry Restoration
Recognition of Physical Plant

Introduction of new Student
Government President

**John Ben Shepperd Leadership
Institute – Outstanding Local Leader
Award**

2 Acceptance of Gift and Resolution
Consideration and possible action on:

Adoption of Resolution Naming The
Arts Center First Floor Lobby Gallery in
Honor of Mary Elizabeth Holdsworth
Butt

3 Executive Session

as provided by Government Code,
Chapter 551.072

Real Estate

Contract and Resolution for Purchase of
Fort Brown Villas Condominium Unit
10F, Type D, Building F, Phase II,
Brownsville, Texas.

Contract and Resolution for Purchase of
Fort Brown Villas Condominium Unit
1A, Type A, Building A, Phase II,
Brownsville, Texas.

Contract and Resolution for Purchase of
Fort Brown Villas Condominium Units
2003, Type C, Building 2, Phase I,
Brownsville, Texas.

**4 Consideration and possible
action on matters discussed in
Executive Session**

Real Estate

Contract and Resolution for Purchase of
Fort Brown Villas Condominium Unit
10F, Type D, Building F, Phase II,
Brownsville, Texas.

Contract and Resolution for Purchase of
Fort Brown Villas Condominium Unit
1A, Type A, Building A, Phase II,
Brownsville, Texas.

Contract and Resolution for Purchase of
Fort Brown Villas Condominium Units
2003, Type C, Building 2, Phase I,
Brownsville, Texas.

5 Approval of minutes of previous meetings

Consideration and possible action on:

Regular Meeting, September 17, 2008

6 Board Briefing

“Why Do Bridges Fall?”

Dr. Sanjay Kumar,
Assistant Professor Engineering

7 Speakers to Agenda Items and Public Discussion

8 Physical Facilities Committee

Consideration and possible action on:

Report

Purchase of a Contract with Design Build Solutions TXMAS-4-56030 for the ITEC Center

Purchase of a Contract with Visual Innovations Company, Inc. TXMAS -4-581010 to Install Audiovisual Equipment for the ITEC Center

Purchase of an Environmental Control, Energy Management and Building Automation System for the Center for Early Childhood Studies

Purchase of Food Service Equipment for the Center for Early Childhood Studies

Purchase of Playground Equipment for the Center for Early Childhood Studies

9 Construction Report

Commissary Building, Newman Center, Cavalry, Memory Park, Palm Trees on Fort Brown Resaca, Palm Trees on University Blvd., Perimeter Fence, ITEC Center, REK Center, Center of Early Childhood Studies, Library, Classrooms, Arts Center

10 President's Report

Working Group Testifies on Human Rights Impacts of Texas/Mexico Border Wall, Grand Opening for Early College High School, Dr. Eloisa Tamez Honored by Texas Civil Rights Project, STEPS Grant, UTB/TSC wins Best Practices in Network Storage Award, UT Health Science Center School of Nursing Dean to Speak, Broad Award, Dr. Jared Diamond Speaks at UTB/TSC, Athletic Updates

11 Proposed Meeting Dates

Board Meetings:
Thursday, November 20, 2008
Tuesday, December 16, 2008

Adjournment

Individuals with disabilities are entitled to have access to and participate in public meetings. An individual requiring an accommodation for access to the meeting must notify the Texas Southmost College District in writing 24 hours prior to the scheduled meeting of the necessity of an accommodation. Upon receipt of this request, the Texas Southmost College District will furnish appropriate auxiliary aids and services when necessary to afford an individual with a disability an equal opportunity to participate in and enjoy the benefits of the Board meeting as non-handicapped individuals enjoy.

THE STATE OF TEXAS §

COUNTY OF CAMERON §

TEXAS SOUTHMOST COLLEGE DISTRICT

RESOLUTION

WHEREAS, Mr. Charles C. Butt and H-E-B have been outstanding friends and supporters of The University of Texas at Brownsville and Texas Southmost College; and

WHEREAS, Mr. Charles C. Butt and H-E-B have been strong advocates for research, economic opportunity development, hunger awareness, education, and the arts; and

WHEREAS, Mr. Charles C. Butt's mother, Mrs. Mary Elizabeth Holdsworth Butt, was a pioneer Valley resident who championed issues of health, justice, and education for people of the Rio Grande Valley; and

WHEREAS, Mrs. Mary Elizabeth Holdsworth Butt was appointed by six different Texas governors to the Texas Board for Mental Health and Mental Retardation; and

WHEREAS, Mr. Charles C. Butt, Mrs. Mary Elizabeth Holdsworth Butt, and H-E-B have strived to serve and improve the quality of life in the Rio Grande Valley for people of all ages for many years through advocacy, education and the arts; and

WHEREAS, music education and the visual and performing arts at The University of Texas at Brownsville and Texas Southmost College and in the Rio Grande Valley will be nurtured in The Arts Center for many years to come;

NOW, THEREFORE, BE IT RESOLVED by the Board of Trustees of the Texas Southmost College District that the Lobby Gallery in The Arts Center will be named

“The Mary Elizabeth Holdsworth Butt Lobby Gallery”

ADOPTED this 30th day of October 2008.

David Oliveira
Chair, Board of Trustees

Roberto Robles, M.D.
Secretary, Board of Trustees

Texas Southmost College District

Minutes of the Regular Meeting of the Board of Trustees

September 17, 2008

The Board of Trustees of the Texas Southmost College District convened in open session on September 17, 2008 at 5:30 p.m., in the Board Room of Gorgas Hall, Texas Southmost College. Board members present were David Oliveira, Chair, Dr. Roberto Robles, Secretary, Chester Gonzalez, René Torres and Adela G. Garza. Absent were Eduardo A. Campirano, Vice Chair, and Rosemary Breedlove. Also present was Dr. Juliet V. García, President of The University of Texas at Brownsville and Texas Southmost College.

Call to Order

The meeting was called to order by Chairman Oliveira at 5:38 p.m.

1. Executive Session

as provided by Government
Code, Chapter 551.072,74

Real Estate

Contract and resolution for
purchase of Fort Brown Villa
Condominiums Unit 7F, Type
G, Bldg F, Phase II,
Brownsville, Texas

Contract and Resolution for purchase of a 0.817 acre tract of land out of Tract 1, Veteran's Area, 5.55 acre tract in Fort Brown Reservation in the City of Brownsville, Cameron County, Texas.

Personnel Matters

Evaluation of the UTB/TSC President

The Board convened in Executive Session at 7:13 p.m.

The Board reconvened in Regular Session at 7:48 p.m.

Consideration and possible action on matters discussed in Executive Session

Approval of contract and resolution for purchase of Fort Brown Villa Condominiums Unit 7 F, Type G, Bldg F, Phase II Brownsville, Texas

A motion was made by Dr. Robles to approve the earnest money contract and resolution for the acquisition of Fort Brown Villas Unit 7F in the amount of \$62,500. The motion was seconded by Mr. Gonzalez and carried unanimously. *Exhibit "A"*

Approval of Contract and resolution for purchase of a 0.817 acre tract of land out of Tract 1, Veteran's Area, 5.55 acre tract in Fort Brown Reservation in the City of Brownsville, Cameron County, Texas

A motion was made by Ms. Garza to approve the earnest money contract and resolution for the acquisition of the 0.817 acre tract of land out of Tract 1, Veteran's Area, 5.55 acre tract in Fort Brown Reservation property in the amount of \$245,000. The motion was seconded by Mr. Torres and carried unanimously. *Exhibit "B"*

Discussion on the Evaluation of the UTB/TSC President

Chairman Oliveira discussed President Juliet V. Garcia's performance for the previous year. He stated that President Garcia has been a true leader for our institution on many occasions this year, but most especially during the biggest challenge UTB/TSC has experienced to date: the Border Wall Fence. Mr. Oliveira stated that he and the other TSC Board members are very satisfied with the leadership role Dr. Garcia has provided the work she has accomplished for the institution. Dr. Garcia affirmed that it has been an honor to work for UTB/TSC, and that she looks forward to continuing her efforts. She thanked members of the Board, faculty, and staff for all their work on behalf of the institution.

1. Approval of Minutes of Previous Meeting

Consideration and possible action on Minutes of Regular Meeting on August 28, 2008

A motion was made by Mr. Gonzalez to approve the Minutes of the Regular Meeting on August 28, 2008. The motion was seconded by Mr. Torres and carried unanimously.

Consideration and possible action on Minutes of the Special Meeting on September 8, 2008

A motion was made by Mr. Torres to approve the Minutes of the Special Meeting on September 8, 2008. The motion was seconded by Ms. Garza and carried unanimously.

2. Resolution

Consideration and possible action on adoption of resolution supporting the Big Read Program for Mexico

Chairman Oliveira called on Doug Ferrier, Dean of Instructional Support, to introduce John Hawthorne. Mr. Hawthorne provided a brief overview of the program, and stated that UTB/TSC is one of two institutions to be awarded a \$20,000.00 grant from the National Endowment for the Arts to expand into Mexico with a pilot program similar to the Big Read Program in Brownsville. The program's objective is to promote literacy by encouraging young students to read and discuss one book per month. The program will additionally improve relations among the Brownsville/Matamoros border communities.

Partnering in this venture with UTB/TSC are the American Consulate to Matamoros and the Mexican Consulate to Brownsville, who were present at the Board meeting. Mr. Hawthorne invited the community to a kick-off event scheduled on October 1, 2008, at the UTB/TSC Library.

Mr. Oliveira read the resolution supporting the Big Read for Mexico.

A motion was made by Mr. Gonzalez to adopt the resolution supporting the Big Read Program for Mexico. The motion was seconded by Mr. Torres and carried unanimously. Exhibit "C"

3. Speakers to Agenda Items and Public Discussion

There were no speakers.

4. Board Briefing

Dr. Charles Dameron, Vice President for Academic Affairs, introduced Dr. Mario Diaz, Director of the Center of Gravitational Wave Astronomy (CGWA). The Center was established in 2003 through a \$6 million NASA grant whose focus was the LISA mission, which employs three satellites for the detection of gravitational waves.

Dr. Diaz described LIGO, for Laser Interferometer Gravitational-wave Observatory. Operating with the LISA mission, LIGO is a fully functional observatory involving optics, lasers, and optoelectronics. LIGO is the most expensive project ever undertaken by the National Science Foundation (NSF), and the NSF Board has recently approved that the CGWA has now expanded to a new experimental phase called Advanced LIGO allowing research in black holes, neutron stars, and the Big Bang.

Dr. Diaz introduced Dr. Malik Rakhmanov, who joined CGWA in January 2008, has several years experience working with the LIGO project. The grant award will allow UTB/TSC to build a facility that will perform research and training in laser, optics, and other related fields. UTB will hire an additional faculty and provide internships for students working with Dr. Rakhmanov and the LIGO project. The LIGO Lab will be located in SETB 1460 and will be approximately 1500 sq. ft. and is expected to be ready by October 2008. The Lab, at UTB will manufacture 3 premode cleaners, and will construct 60 optical levers for Advanced LIGO. The facility is expected to be fully operational by 2012.

Dr. Diaz outlined his vision for the future of the LIGO project including the establishment of a prospective partnership with SEMTECH, a manufacturer located in Reynosa, Mexico that makes semi-conductors. He added that he

imagined the possibilities being similar to Southwest Regional Institute in San Antonio, which employs over 3,100 researchers and has an annual revenue of over \$500 million.

5. Bond Projects –Purchase of an Environmental Control, Energy Management and Building Automation system for the Center for Early Childhood Studies

After a brief discussion, this item was tabled.

6. Tax Rate–Adoption of the 2008 TSC District Ad Valorem Tax Rate

Dr. David Pearson, Vice President for Partnership Affairs, introduced Melba Sanchez, Assistant Vice President for Finance, to provide an overview of the 2008 tax adoption. Ms. Sanchez stated that according to the Texas Constitution and the Property Tax Code, the concept of truth-in-taxation requires the District to comply with certain steps in adopting its tax rate. The District has taken the necessary steps toward adopting a tax rate for 2008 by calculating and publishing the effective and roll back tax rates, discussing the tax rate, and holding two public hearings. During that process, the District identified its needs for the upcoming fiscal year and has adopted a budget to meet those needs. The taxes necessary to cover those needs require the adoption of a tax rate of \$ 0.161089 per \$100 valuation.

**Consideration and possible action on the adoption of
2008 TSC District Ad Valorem Tax Rate**

A motion was made by Ms. Garza to adopt a maintenance and operations tax rate of \$0.110614 and a debt tax rate of \$0.050475 per \$ 100 valuation. The motion was seconded by Dr. Robles and carried unanimously. Exhibit “D”

7. Construction Report

Dr. Pearson reported the following:

- The Cavalry Building renovation for the Center for Gravitational Wave Astronomy wing is nearing completion. The wiring system has been installed. The door frames and doors have arrived and are being installed. Final painting on the wainscoting and molding is expected to be completed by next month.

Ms. Mendez reported the following:

- The exterior brick for the ITECC's main entrance will arrive within the next two weeks. The interior finishes are nearly completed. The tile floor and classroom board have been installed. Carpeting for the lecture halls, classrooms, and offices have been completed. The mechanical system for the Broadcast studio is near completion. The center courtyard ceiling finishes have been completed. The completion date for the ITECC is on December 2008.
- Construction continues at the REK Center. The brick and air conditioning ducts have been installed. The swimming pool is starting to take shape. The wall floating, painting, and texturizing is almost complete.
- Construction continues at the Center for Early Childhood Studies. Mud has been causing delays but two Casitas, #2 and #4 are taking shape. Concrete for Casita #4 is being poured.
- Construction at the New Library and Classroom building continues. The 2nd floor is ready for concrete to be poured and windows are being installed. Roof work is in progress.
- Construction continues at the Arts Center. The Performance Hall is completed. The crane has arrived and is staged on site and ready to erect steel for the next six weeks.

8. President's Report

Dr. Garcia reported the following:

- Dr. García recognized the Alumni Association for their success in raising \$12,500 within a three year period. The Houston Endowment matched those funds for a student scholarship endowment now valued at \$35,000. The association has been awarding one \$500 scholarships per semester for the past three semesters. During the current fall semester they awarded two \$500 scholarships for a total of \$2,500 to date. Recently the Association was offered an opportunity to receive matching funds in the amount of \$10,757 from the Greater Texas Foundation for a second scholarship endowment. Dr. Garcia congratulated Olga Garcia, President of the Alumni Association, and The Association's members for providing scholarship funding for UTB/TSC students.

- The Center for Civic Engagement, in conjunction with the Office of the President and the League of Student Voters at UTB/TSC, began a voter registration drive on Monday, September 15, 2008, at various site locations on campus. Monday, October 6, 2008, is the deadline to register to vote for the November General Election. Dr. Garcia noted that volunteers will be on site to register voters during the week of September 29, 2008.
- The UTB/TSC campus will be a site for early voting on Election Day, November 4, 2008. Early voting begins Monday, October 20, through Friday, October 24, 2008.
- Dr. Garcia encouraged all students, staff, faculty and community members to vote on campus. She noted that without good voter turnout, our campus is in danger of a losing its status as an early voting site.
- Dr. García congratulated Dr. Hilda Silva, Vice President for Student Affairs, and Dr. Sylvia Leal, Assistant Vice President for Student Affairs, for hosting the Disney Institute earlier this month, in the Student Union's Gran Salon. More than 200 Valley residents and businesses attended the "Business Behind the Magic," a seminar about the Disney success and how these valuable keys can be incorporated into one's own success.
- Dr. García announced a new Early College High School partnership between UTB/TSC and the Brownsville Independent School District. More than 100 freshmen have begun the program at Clearwater Elementary School where they were greeted by ECHS first principal, Roni Louise Rentfro. The Early College concept is that by the time the students graduate they will have a high school diploma and an associates degree from UTB/TSC. A ribbon cutting ceremony is scheduled on Thursday, October 9, 2008, at 10:00 am, at the BISD Central Administrative Building.
- Dr. García announced that the Patron of the Arts is in its 24th season this month with several gifted artists scheduled to perform. Ricardo Delgado Herbert, baritone, and James Pulles, pianist will perform a concert of 19th century songs on September 20, 2008, in the SET B lecture Hall, at 8:00 pm.

The Faculty and Students Hispanic Heritage Concert is scheduled on September 27, 2008, at SET B Lecture Hall, at 8:00 pm.

- The art season kicked off with James C. Miller, a contemporary South Texas artist trained in flatbed scanned photography and art instillation. The exhibit runs through September 27, at the Rusteberg Art Gallery.

The Talent and Inventive Exhibit will follow from September 30, 2008, through October 8, 2008, at the Rusteberg Art Gallery.

- Dr. García invited the public to the Distinguished Lecture Series. Our guest speaker, Dr. Jared Diamond, The Pulitzer Prize–winning author of *Guns, Germs, and Steel: The Fates of Human Societies*, is featured at the 10th annual Distinguished Lecture Series, to be held on October 16, 2008, at 7:00 pm, in the Science and Engineering Technology Building Lecture Hall. Dr. Diamond will also help us recognize the winners of the high school essay competition on the topic of “Globalization: For Better or Worse! Touching On Why Societies Succeed and Fail.” The top three winners will receive prizes of \$250, \$200, and \$150, and an additional seven finalists will receive \$100. The students will be recognized at the student lecture given by Dr. Diamond on October 17, 2008.

9. Proposed Meeting Dates

Thursday, October 30, 2008

Thursday, November 20, 2008

Thursday, December 16, 2008

10. Announcements

Dr. García introduced the recipients of the Houston Endowed Chairs the largest philanthropic foundation in Texas. They gifted \$1.58 million in 2003 to sponsor two endowed chairs, which have three year terms and are funded at \$25,000 annually. She introduced the two most recent recipients of the Houston Endowment Chairs: Dr. Manuel Medrano and Dr. Bobbette Morgan.

Dr. Medrano has been a faculty member in the School of Liberal Arts where he has been a History professor since 1972. He will utilize the award to continue the “Los Del Valle” history project. Dr. Medrano thanked Dr. García, faculty, and students for their ongoing support.

Dr. Bobbette Morgan, an Associate Professor for Curriculum and Instruction, joined UTB/TSC in 2000, and is the first Director of Doctoral Programs in the School of Education. She also led the effort to create the first doctoral program with an emphasis in Bilingual Studies. Dr. Morgan plans to use the award to bring speakers and promote conferences where professors with similar interests can meet. She thanked Dr. García, faculty, and students.

Dr. García introduced Dr. Vince Solis Assistant Vice President for Student Affairs. Dr. Solis introduced Rusty Harwood, Chess Program Director, and recognized student champions Danny Fernandez and Arturo Gracia, Jr., from the UTB/TSC Chess Club.

Adjournment

The meeting was adjourned by Chairman Oliveira at 8:27 p.m.

David G. Oliveira
Chairman, Board of Trustees

Roberto Robles, M.D.
Secretary, Board of Trustees

NOTE: The tape of the Regular Board of Trustees meeting held on September 17, 2008 is on file at the District Office of the Texas Southmost College District. The master tape is on file at the UTB/TSC Media center. These minutes were taken and transcribed by Gloria Miranda, Administrative Assistant. Videotaping of the Board of Trustees' meetings began on April 11, 1996. They are aired on Channel KBSD in cooperation with the Brownsville Independent School District.



TEXAS SOUTHMOST COLLEGE DISTRICT

BOARD AGENDA REQUEST FORM

Department/Division: Office of Planning and Construction / Partnership Affairs.	Board Meeting Date: October 30, 2008
Agenda Item: Consideration and possible action on a purchase of a contract with Design Build Solutions TX MAS -4-56030 for the ITEC Center.	
Rationale/Background: At the request of Texas Southmost College, Design Build Solutions, a Garland Company, provided a cost estimate for the replacement of the skylights at the ITEC Center. Design Build Solutions, a Garland Company, has been providing roof repair services for the ITEC Center through a TXMAS contract. By using their services through TXMAS, Texas Southmost College has realized savings to the ITECC project. Due to the deteriorated condition of the skylights it is recommended to contract Design Build Solutions to replace them. The attached proposal in the amount of \$87,764 includes all materials and services for the replacement of the skylights.	
Recommended Action: Motion to accept proposal from Design Build Solutions, a Garland Company, in the amount of \$87,764 and authorize the Assistant Vice President for Planning and Construction to execute the contract.	
Fiscal Implications: Budgeted Item: Yes <input checked="" type="checkbox"/> No <input type="checkbox"/> N/A <input type="checkbox"/> If no, explain: Funding from interest earned on maintenance notes	
Attachments (List): 1. Recommended Proposal 2. Skylight Floor Plan	

FOR OFFICE USE ONLY:
Board Action: Approved: <input type="checkbox"/> Yes <input type="checkbox"/> No <input type="checkbox"/> N/A <input type="checkbox"/> Tabled for action on: _____
Certified by: _____ Title: _____ Date: _____



TXMAS-4-56030
TXMAS-4-56030-1



2800 East 91st Street, Cleveland, Ohio 44105 • 866-327-0300 • www.design-buildsolutions.com

ROOFING MATERIAL AND SERVICES PROPOSAL

UNIVERSITY of TEXAS at BROWNSVILLE
TSC – WEST CAMPUS – ITECC
SKYLIGHT REPLACEMENT
Proposal Date: October 14, 2008
Quote #: TXM-TX-2008.052

Purchase Request / Delivery Order Language:
 The Garland Company, Inc. (dba) Design-Build Solutions, Inc * TXMAS-4-56030-1

THE FOLLOWING PROPOSAL (S) ARE SUBMITTED IN ACCORDANCE TO THE ACCOMPANYING PROJECT DOCUMENTS INCLUDING BUT NOT LIMITED TO; DETAILS AND DRAWINGS, PROJECT MANUAL AND SYSTEM SPECIFICATIONS, SCOPE OF WORK.

Proposed Scope of Work:

- Remove and Install with new - (4) 5'x 5' skylights
- Remove and Install with new – (6) 10' x 30' skylights
- Skylight construction includes built-in OSHA metal safety guard railing.

ITEM#	DESCRIPTION	UNIT LOT	UNIT COST	EXTENSION AMOUNT
1	MATERIALS	1		\$ 450.45
	DESCRIPTION	SQ. FT.	AMOUNT / SF	AMOUNT
2	ANCILLARY SERVICES Sold in Conjunction with Garland material	N/A	N/A	\$ 87,313.55
3	TOTAL AMOUNT	N/A	N/A	\$ 87,764.00

TXMAS-4-56030
TXMAS-4-56060-1



Norm Crawford, CART, CSI-CDT
South Central Regional Manager
Design-Build Solutions, Inc.

Accepted by:

Signature: _____

Printed Name: _____

Title: _____

Pricing is valid for ninety days (90) from the date of this proposal.

Communication relating to this proposal may be directed to:
Norm Crawford, CART, CSI-CDT
18178 Windy Oaks Ct.
Porter, TX 77365
281-825-7625
281-354-1173 fax
ncrawford@garlandind.com

END OF PROPOSAL



TEXAS SOUTHMOST COLLEGE DISTRICT

BOARD AGENDA REQUEST FORM

Department/Division: Office of Planning and Construction / Partnership Affairs.	Board Meeting Date: October 30, 2008
Agenda Item: Consideration and possible action on the purchase of a contract with Visual Innovations Company, Inc. TXMAS 4-581010 to install audiovisual equipment controls for the ITEC Center.	
Rationale/Background: As the ITECC project nears completion, it is time to install equipment at the classrooms. As per our classrooms standards, a fully integrated audio visual equipment package is required for a functional classroom. Visual Innovations is a TXMAS vendor that specializes in audio visual system integration. The proposal amount of \$80,905.23 includes all equipment and labor required for a fully functional audio and visual system for 11 classrooms at ITECC	
Recommended Action: Motion to accept proposal from Visual Innovations Company, Inc. in the amount of \$80,905.23 and authorize the Assistant Vice President for Planning and Construction to execute the contract.	
Fiscal Implications: Budgeted Item: Yes <input checked="" type="checkbox"/> No <input type="checkbox"/> N/A <input type="checkbox"/> If no, explain: Funding from interest earned on maintenance notes	
Attachments (List): 1. Recommended Proposal 2. Classroom Floor Plan	

FOR OFFICE USE ONLY:
Board Action: Approved: <input type="checkbox"/> Yes <input type="checkbox"/> No <input type="checkbox"/> N/A <input type="checkbox"/> Tabled for action on: _____
Certified by: _____ Title: _____ Date: _____

Visual Innovations Company, Inc

Visual Innovations Company Inc.
Corporate Office

8500 Shoal Creek Blvd, Bldg 1
Austin, Texas 78757
Phone (512) 334-1100
Fax (512) 334-1133

Audio Visual Proposal
For

UTB/TSC
ITEC Center

Quote Date: 10/23/08

Quotes expire in 30 days.

NONE Project Expedite Surcharge

8-8 Weeks Standard lead time for install
ARO

UTB		UTB/TSC	
ORGANIZATION Patricia Sanchez	_____ Purchase Order (*Approved Customers)	ORGANIZATION Patricia Sanchez	
CONTACT 80 Fort Brown	PO # _____	CONTACT ITEC Campus 301 Mexico Blvd	
ADDRESS Brownsville TX 78520	_____ COD	ADDRESS _____ SUITE	
CITY STATE ZIP 956-882-4311 956-882-4316	_____ Credit Card (Below)	CITY STATE ZIP 956-882-4311 956-882-4316	
PHONE FAX		PHONE FAX	
TERMS	QUANTITY	DESCRIPTION	UNIT PRICE
TBD	N/A	N/A	Mayo Deleon
			Net 30

AV Classrooms Room

Sub-total

E110	\$	6,481.11
E122	\$	4,635.68
E120 Medium	\$	6,588.76
E112	\$	6,481.11
D112 Medium	\$	6,588.76
D114 Medium	\$	6,588.76
E104	\$	10,895.11
D102	\$	10,895.11
E106 Medium	\$	6,588.76
E102	\$	4,720.68
E108 Medium	\$	6,588.76
 Sub-Total	 \$	 77,052.60
Integration Contingencies	\$	3,852.63
 Grand Total	 \$	 80,905.23

TXMAS Contract # TXMAS-4-581010

Visual Innovations Company, Inc

Visual Innovations Company Inc.
Corporate Office

8500 Shoal Creek Blvd, Bldg 1
Austin, Texas 78757
Phone (512) 334-1100
Fax (512) 334-1133

Audio Visual Proposal
For

UTB/TSC
ITEC Center

Quote Date: 10/23/08
Quotes expire in 30 days.

NONE	Project Expedite Surcharge
8-8 Weeks	Standard lead time for install ARO

UTB/TSC	UTB/TSC	UTB/TSC
ORGANIZATION Patricia Sanchez	Purchase Order (*Approved Customers)	UTB/TSC ORGANIZATION Patricia Sanchez
CONTACT 80 Fort Brown	PO #	CONTACT ITEC Campus 301 Mexico Blvd
ADDRESS Brownsville TX 78520	COD	ADDRESS SUITE Brownsville TX 78520
CITY STATE ZIP 956-882-4311 956-882-4316	Credit Card (Below)	CITY STATE ZIP 956-882-4311 956-882-4316
PHONE FAX		PHONE FAX
Term	Term	Term
TBD	N/A	N/A
	Mayo Deleon	
		Net 30

Visual Innovations TXMAS contract info: TXMAS-4-581010

Contract period: 10/24/2003 - 04/07/2012

Visual Innovations Company, Inc., operating under TXMAS Contract # TXMAS-4-581010 as a TXMAS contractor.

SCOPE OF WORK:

Room will be installed with six recessed ceiling speakers and dual amplifiers to cover area. An Extron Pole Mount System will be installed with 2 vga inputs and 2 video inputs. A DVD controller will be added to the system. Equipment will be mounted in customer furnished lectern. Lectern will have rack rails installed. Mounted on the rails will be a clamping shelf for the DVD/VCR player, an Extron AAP rack plate for inputs (2 USB AAP with cables connected to customer computer, power/data AAP, PVS Video, PVS VGA) to be mounted, power supply and open space below for the PC.

OWNER FURNISHED EQUIPMENT:

Existing installed screen, projector, lectern w/PC and monitor.
Conduit from floor box, stubbed up to ceiling area minimum 1"
Power to lectern and rack
Data to lectern for Extron, and data port

Customer Acceptance for scope of work:

I have read and accept the Scope of Work. I understand that Visual Innovations does not contract or supply electrical, sheetrock or paint work.

Customer Signature _____ Date _____

Printed Name _____

ATTACHMENT A - EQUIPMENT LISTING

Brand	Model	Part #	Description of products and services proposed
Extron	AAP 302	60-633-02	Full Rack Width, 2u Faceplate
Extron	Dual USB AAP	70-383-11	Two USB A Female to USB B Female Adapters
Extron	MPA 181T	60-747-01	70 Volt Amplifier
Extron	AC AAP	70-211-01	AC Outlet and RJ-11/RJ-45 AAP-Architectural Adapter Plate For HSA Products
Extron	IDCM DV+	70-220-02	Enhanced DVD IR Control Module
Extron	AAP 102	60-300-02	Two Gang Architectural Plate
Extron	PVS 204SA Plus	60-885-01	Polevault 4 Input Custom Equipment
Extron	SI 3CT LP	42-103-01	70V Recessed Ceiling Speakers
Extron	PVT CV D	60-910-05	Pole Vault Video Transmitter
Extron	PVT RGB D	60-911-05	Pole Vault VGA Transmitter
Extron	PVT CV AAP	70-579-12	Pole Vault Video AAP Transmitter
Extron	PVT RGB AAP	70-580-12	Pole Vault VGA AAP Transmitter
Extron	MLC 104	60-818-02	Media Link Controller w/P Link
Extron	VLM 2000	42-139-02	Infrared Wireless Dual Microphone For Use With Polevault
Extron	PCM 240	60-772-03	Projector Ceiling Mount
Extron	PML 450	70-618-03	Easy Install Projector Mounting Kit
Furman	M-8	M-8	Power Conditioner, 8 Outlet, 120v/15a
MAP	RC-2	RC-2	2 Space Clamping Shelf
MAP	RRF10	RRF10	Pair 10 Space (17 1/2") Full-hole Rack Rail, Black Powder Coat Finish
Sony	SLV-D380P	SLV-D380P	DVD/CR Combination

Visual Innovations Company, Inc

AV SYSTEMS INTEGRATION TERMS AND CONDITIONS

System Implementation

VI will provide a turnkey system to include equipment, implementation and warranty, as defined on the attached Scope of Work and Project Quote. Our Installation includes engineering, coordination and labor for display, video, and related equipment to include required plates, connectors and cables.

System Engineering, including:

- Preparation of system functional interconnection diagram.
- Facility and equipment location.

Project Coordination, including meetings with the client's technical representatives and project coordination, including:

- System implementation monitoring.
- Schedule project and oversee the VI team
- Equipment staging at our shop
- Assure final punch-list items are completed

Field Labor, including:

- Pulling and bundling cables
- Terminating of all cable
- Labeling all cable
- Mounting and terminating computer interfaces
- Installing structural systems for multimedia equipment
- Program control System
- Adjusting and balancing audio settings
- Assure that the installed systems functions as proposed
- Site clean up and rubbish disposal
- Provide end-user training

Inclusions

- All equipment, wire and accessories required for a fully functional audio and visual system.
- Labor associated with turnkey engineering, installation, programming, testing and training.
- Documentation package including as-built system CAD diagrams and Operation & Maintenance manuals.
- Coordination and cooperation with the construction team in regards to installing the system.
- Upon request, VI shall furnish a one-year maintenance contract and proposal.
- User training on system operation.
- Any additional trips, labor or materials due to failure of the other work forces to have the audio/visual system rough-in work completed as anticipated and previously confirmed, will be added to the project billing as required.
- DMX, DSS or other outside signals (provided by others) are not included in this scope of work, however VI shall integrate up to two pre-approved source equipment's outputs into the systems that VI is providing, and additionally shall provide basic control of these devices.
- The owner's architect will provide VI's engineering department with all required architectural floor, reflected ceiling, building elevation, and section plans in Auto Cad format at no charge to VI.
- This quotation is valid for 30 days. VI reserves the right to modify our quotation pricing if not accepted within 30 days of this quotation date.
- This quotation is based installations at the specified sites set forth in the customer's requirements. If this configuration is to be used at other sites, travel expenses may apply.

Exclusions

The following is not included in our scope of work:

- All conduit, high voltage wiring panels, breakers, relays, boxes, receptacles, etc. Any related electrical work, including but not limited to 110VAC, conduit, core drilling, raceway and boxes except those specifically quoted.
- Voice/ data cabling, IE analogue phone lines, ISDN lines, network ports, etc.
- Network connectivity, routing, switching and port configuration necessary to support audio-visual equipment except as specifically quoted.
- Concrete saw cutting and / or core drilling.
- Fire wall, ceiling, roof and floor penetration, patching, removal or fire stopping.
- Necessary sheet rock replacement and or repair.
- Necessary ceiling tile or T-bar modifications, replacement and/or repair.
- Any and all millwork (moldings, trim, etc.). All millwork or modifications to project millwork to accommodate the AV equipment is to be provided by others unless otherwise noted in this proposal
- Painting, patching or finishing of architectural surfaces.
- Permits (unless specifically provided for elsewhere in the contract).
- HVAC and plumbing relocation.
- Rough-in, bracing, framing, or finish trim carpentry for installation.
- Cutting, structural welding, or reinforcement of structural steel members required for support of assemblies, if required
- Any applicable taxes, permits or bonds related to the project. All normal shipping costs not part of original quote, added as a pass through cost to progress billing.
- Unless otherwise specified, the warranty provisions in this contract do not cover Owner furnished equipment. In addition, owner furnished equipment shall not be controlled unless otherwise stated in the inclusions (above).
- Owner furnished equipment or equipment by others that is integrated into the systems (as described above) is assumed to be current industry acceptable equipment in good working order. If it is determined that this equipment is faulty upon installation or adversely affects the system, additional project charges may be incurred.
- Note: VI will discuss the effects of exclusions on the work to be performed prior to beginning the installation

Standard Warranty

VI warrants the Audio-Visual System furnished to be free from defects in workmanship (i.e. cables, connections, structures) failure for a period of 90 days from the date of acceptance or first beneficial use, whichever occurs first. Warranty service for such defects will be handled in a reasonable and timely manner from the time of notification to VI by the Owner or their agent. (See Warranty Statement)

Manufacturer's equipment warranties are of varying lengths (usually 90 days to 1 year). VI will warranty this equipment for the term established by the manufacturer on a depot basis only. Deliver warranty repair equipment to VI, Attention: Service Department. Please include a copy of this form with each piece of equipment.

Warranty does not apply to any product that has been subject to misuse, neglect, accident or operational error.

Customer Initials _____

Visual Innovations Company, Inc

AV SYSTEMS INTEGRATION TERMS AND CONDITIONS - CONTINUED

Control System Source Code

Visual Innovations Company does not routinely provide our customers with control system source code. "Source Code" is defined as the actual, editable programming language statements, whether contained in a single file, multiple files, include files or library files. Visual Innovations provides the "Object Code" which is the machine interpretable program capable of executing or running the target system.

The Source Code will be provided under the following conditions:

- The customer must agree in writing to purchase the source code prior to any code development by Visual Innovations Company.
- The source code does not contain any software or code that Visual Innovations Company has purchased or licensed that would violate any license agreement Visual Innovations Company has with a third party author or manufacturer.

All AMX and Crestron control system source code developed by Visual Innovations Company is to remain the property of Visual Innovations, unless specified under project contract to be provided to the customer with the final installed AV system. Copies of compiled programs will be provided to the customer on CD along with manuals and system warranty information.

Integrated Systems – Standard Terms and Conditions

Scope of Work for the Project

In this document the term "Owner" shall mean client or awarding party. VI shall execute the project work described in the included proposal and/or quote concerning the Owner's system integration work. The scope work is based upon information provided by the Owner. As the project work progresses, agreement on modifications may be necessary to complete the project. These additions, deletions and/or adjustments in time shall be considered change orders and when mutually agreed upon in writing by both parties, shall become part of the agreement.

The terms and conditions of this agreement, and those terms and conditions contained in any appendices or approved change orders to this agreement, together shall form the entire purchased order or agreement. Request for quotation, acceptance or other purchasing documents which are inconsistent with, different from or in addition to the terms and conditions of this agreement shall be considered void. This agreement shall take precedence over all previous oral discussions or prior understanding between both parties.

This agreement and all Owner purchase documents are subject to acceptance by VI, including if appropriate, approval by VI's credit department. VI reserves the right to cancel this agreement, if the Owner fails to meet credit requirements.

Agreement Sum and Taxes

The Owner shall pay VI in current U.S. funds for the performance of the project work per the agreement sum, which may be adjusted, subject to mutually agreed upon additions and deletions provided within the agreement.

The prices for equipment are subject to taxes, including but not limited to sales, excise or use taxes. The Owner shall pay all sales, use ad valorem, excise and/or other taxes imposed on either party. Owner shall not pay for taxes based upon VI's income. If applicable, the owner shall provide a tax-exempt certificate at the time of acceptance of contract. VI will invoice for all applicable taxes that VI is legally obligated to collect from the Owner.

Time

VI's proposal for installation and services is based upon our normal 8-hour business day / 40-hour business week, Monday through Friday, between the hours 8:00am to 5:00pm, excluding VI holidays, unless otherwise stated within our proposal. VI shall be compensated for installation and services beyond normal business hours or business days, on an overtime rate basis when mutually agreed upon. Should VI be delayed in the progress and performance of the work due to material changes, labor disputes, fire or usual delay in deliveries, construction delays, unavoidable casualties or causes beyond VI's control, the agreed upon time for completion shall be extended by change order. These change orders may also include charges to cover additional costs incurred by VI due to the delay.

Payment Terms

Subject to credit approval, the Owner shall pay VI within ten (10) days of invoice date. All project work requires a minimum deposit of thirty percent (30%) of the overall agreement total to initiate the order. Deposits are due upon receipt of invoice. Project timeline schedules will begin upon receipt of the deposit or initial payment.

Systems Integration work where procurement, installation and completion of the work extend beyond a period of greater than ten (10) days from the date of the order, will be subject to progressive billing or invoicing. In such cases VI will progressively invoice for hardware, equipment and materials received, stored and assigned to the project, along with a percentage of completed labor and services. Progressive billing or invoices are due and payable per VI normal credit terms of Net ten (10) days.

Finance Charge / Costs of Collection

If the Owner fails to pay VI for equipment and/or services when due, VI under this agreement shall be allowed to invoice Owner for monthly finance charges equal to one and one-half percent (1.5%) of any amounts past due, chargeable for each month that the payment is outstanding.

Changes / Returns / Cancellation

Any changes or modifications to the agreed upon scope of work defined in the proposal must be mutually agreed upon in writing. Formal change orders shall document these modifications.

Should Owner cancel a project in whole or in part, prior to completion, the Owner agrees to pay VI for all costs incurred to date and/or to bring the project to a mutually acceptable close. These costs are, but are not limited to: the design and engineering services; Project management; the installation and programming; technical labor; subcontracting expenses; the materials and equipment costs; and all other miscellaneous documented costs. Materials and equipment are also subject to restocking fees.

Customer Initials _____



Visual Innovations Company, Inc.
Standard Warranty/Workmanship Guarantee

VISUAL INNOVATIONS COMPANY, INC. (VI) LIMITED WARRANTY

Standard 90 day Manufacturer's Warranty Service

MANUFACTURER'S WARRANTY SERVICE: If any products provided to the initial end-user customer should become defective within 90 days of delivery or installation by VI, VI will act on the behalf the customer to obtain repair or replacement from the manufacturer, provided that product is eligible for manufacturer's warranty coverage. Products covered during the manufacturer's warranty period are the responsibility of the manufacturer. This Manufacturer's Warranty Service is inclusive of the manufacturer's warranty; it does not replace the manufacturer's warranty, but provides certain additional benefits during the term of the manufacturer's warranty. During the warranty period, Purchaser will either return the defective product; freight prepaid to the manufacturer, or deliver it to VI at the address listed below. The Product to be repaired is to be returned in either its original carton or a similar package affording an equal degree of protection. VI will return the repaired product freight prepaid to Purchaser, on behalf of the Purchaser, at any time during the 90 day Workmanship Warranty period. In the absence of an Extended Service Agreement, all freight, labor and administrative costs incurred by VI associated with replacement of warranty parts after expiration of the original Workmanship Warranty period are the responsibility of the Purchaser, and will be billable to the Purchaser at VI's prevailing rates at the time of such service.

In the absence of an Extended Service Agreement, VI is not obligated to provide Purchaser with a substitute unit during the warranty period or at any time. For an additional fee, VI will provide field service and support at the Purchaser's location at VI's prevailing billable rates for such service, subject to availability.

Standard 90 day Warranty against defects in Materials and Workmanship

ITEMS COVERED: VI warrants to the initial end-user customer of the Integrated System/Installation Services will be free from defects in material and workmanship for 90 days from date of substantial completion. Projector lamps or other consumables are not covered under this warranty but may be covered under the manufacturer's warranty.

VI'S PLEDGE TO CORRECT PROBLEMS UNDER WARRANTY: During the 90 day Workmanship Warranty period, at our option, VI will either repair or replace the in-warranty defective unit without charging the customer. When parts or products are exchanged under warranty the item(s) replaced will automatically become VI's property. In order to make repair or exchange under warranty VI may elect to use new parts or those reconditioned to the manufacturer's exacting standards of performance and quality. Once an item has been repaired under warranty it assumes the remaining period of warranty based upon original date of purchase. This warranty covers hardware, materials and workmanship related issues and does not include any necessary labor for maintenance or service.

NOT COVERED UNDER THIS WARRANTY: End-users of these products will not have any claim under this warranty for repair or adjustment expense if:

1. The equipment or materials is maltreated in anyway and the problem has been caused by improper or careless treatment.
2. The problem is caused by fire or other natural calamity
3. The problem is caused by improper repair or adjustment by an unauthorized service provider
4. Problems caused by unauthorized operation or installation
5. Damage caused in shipping
6. The serial number label or other identifying marks (name plates and logos) are removed
7. The proof of purchase is not submitted with the claim
8. Ownership of the product has changed (this warranty is non-transferable)
9. The warranty period has expired

DISCLAIMER OF WARRANTY

EXCEPT FOR THE FOREGOING WARRANTIES, VI HEREBY DISCLAIMS AND EXCLUDES ALL OTHER WARRANTIES, EXPRESS OR IMPLIED, INCLUDING, BUT NOT LIMITED TO ANY AND/OR ALL IMPLIED WARRANTIES OF MERCHANTABILITY, FITNESS FOR A PARTICULAR PURPOSE AND/OR ANY WARRANTY WITH REGARD TO ANY CLAIM OF INFRINGEMENT THAT MAY BE PROVIDED IN SECTION 2-312(3) OF THE UNIFORM COMMERCIAL CODE AND/OR IN ANY OTHER COMPARABLE STATE STATUTE.

LIMITATION OF LIABILITY

THE LIABILITY OF VI, IF ANY, AND PURCHASER'S SOLE AND EXCLUSIVE REMEDY FOR DAMAGES FOR ANY CLAIM OF ANY KIND WHATSOEVER, REGARDLESS OF THE LEGAL THEORY AND WHETHER ARISING IN TORT OR CONTRACT, SHALL NOT BE GREATER THAN THE ACTUAL PURCHASE PRICE OF THE PRODUCT WITH RESPECT TO WHICH SUCH CLAIM IS MADE. IN NO EVENT SHALL VI BE LIABLE TO PURCHASER FOR ANY SPECIAL, INDIRECT, INCIDENTAL, OR CONSEQUENTIAL DAMAGES OF ANY KIND INCLUDING, BUT NOT LIMITED TO, COMPENSATION, REIMBURSEMENT OR DAMAGES ON ACCOUNT OF THE LOSS OF PRESENT OR PROSPECTIVE PROFITS OR FOR ANY OTHER REASON WHATSOEVER.

To obtain warranty service instructions, verify the problem and obtain Return Merchandise Authorization (RMA) number, please call Visual Innovations Company, Inc. technical support at 1-866-493-4169

NOTE: Any product returned without an RMA number will be refused upon delivery. For trouble shooting or to enquire about extended service warranties, please call the number listed above or visit our website – www.vicav.com

Visual Innovations Company, Inc.
8500 Shoal Creek Blvd, Building 1, Austin, Texas 78757 USA

November 3, 2004



TEXAS SOUTHMOST COLLEGE DISTRICT

BOARD AGENDA REQUEST FORM

Department/Division: Office of Planning and Construction / Partnership Affairs.	Board Meeting Date: October 30, 2008
Agenda Item: Consideration and possible action on the purchase of an environmental control, energy management and building automation system for the Center for Early Childhood Studies.	
Rationale/Background: Owner procurement of materials was identified as one of the cost control strategies for the construction projects. Procurement of an environmental control, energy management and building automation system was identified as one of the items that could provide additional savings to the Center for Early Childhood Studies project if procured by the owner. The attached proposal includes a detail description of the system with TX MAS pricing. The attached proposal represents savings of approximately \$11,000 to the project.	
Recommended Action: Motion to accept proposal from Siemens Building Technologies, Inc. in the amount of \$63,550.00 and authorize the Assistant Vice President for Planning and Construction to execute the contract.	
Fiscal Implications:	Budgeted Item: <input checked="" type="checkbox"/> Yes <input type="checkbox"/> No <input type="checkbox"/> N/A If no, explain:
Attachments (List): 1. Recommended Proposal	

FOR OFFICE USE ONLY:
Board Action: Approved: <input type="checkbox"/> Yes <input type="checkbox"/> No <input type="checkbox"/> N/A <input type="checkbox"/> Tabled for action on: _____
Certified by: _____ Title: _____ Date: _____

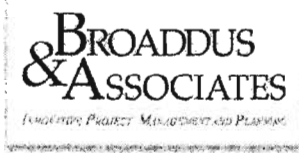

RECOMMENDATION LETTER.

To: Ms. Diana Bravo Gonzalez
Bond Project Manager

From: Mr. Joe Rafac
Procurement Specialist/Cost Analyst

Date: October 3, 2008

RE: Purchase of Energy Management Automation System for the Center for Early Childhood Studies.

The quote number 082008-00000-0005 received from Siemens Building Technology Inc. contain all the materials that the University specified in section 15950- Facility Management System of the Construction Documents for the Center for Early Childhood Studies project prepared by Wells Janousek Architects.

Prices submitted by Mr. James Knight of Siemens have been verified that are the correct TXMAS prices. By using this purchasing mechanism the University will potentially save \$11,000.00 over normal contractor pricing.

I recommend approval to purchase the Energy Management Automation System for the Center for Early Childhood Studies projects in the amount of \$ 63,550.00 from **Siemens Building Technology Inc.**

I agree Disagree

Diana Bravo Gonzalez 10-3-08
Ms. Diana Bravo Gonzalez / Date

SIEMENS

Siemens Building Technologies Inc.
12001 Network Blvd. Suite 318
San Antonio, Texas 78249

phone (210) 641-2921
fax (210) 641-2922

Proposal # 2651-02
Quote ID:082008-00000-0005

Diana Bravo-Gonzalez
Broaddus & Associates, Inc.

No.: 2651-02
Date: October 2, 2008
Limiting Date:

Project: UTB/TSC Center for Early Childhood Studies
Architect: Wells Janousek
Engineer: Halff & Associates, Inc.
Proposal: We propose to furnish a Siemens Building Technologies, Inc., environmental control, energy management and/or building automation system for the above job in accordance with the below scope of work.

Net Price: \$ 63,550.00
Sixty-Three-Thousand-Five-Hundred-and-Fifty DOLLARS

- Remarks:
1. Based on TXMAS Contract # TXMAS-8-84030
 2. CONTROLS FOR 5 AHU'S, 8 VAV BOXES, 2 PUMPS & 5 EXHAUST FANS. EXCLUDES VFD'S, SMOKE DETECTORS. ETHERNET PORTS PROVIDED BY OWNER
 3. See attached scope of work for details by building.
 4. Other exclusions and differences: Sales tax has been excluded

The Terms and Conditions of Sale shown on the attached are a part hereof

Proposal Accepted:
Siemens Building Technologies, Inc. is authorized to proceed with the work as proposed.

Proposal Submitted:
Siemens Building Technologies, Inc.

Purchaser _____
By _____
Title _____
Date _____

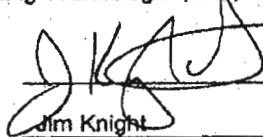
Seller  _____
By Jim Knight _____
Title Account Executive _____
Date October 2, 2008 _____

This proposal is valid until _____
Page 1 of 2

SIEMENS

Siemens Building Technologies Inc.
12001 Network Blvd. Suite 318
San Antonio, Texas 78249

phone (210) 641-2921
fax (210) 641-2922

Proposal # 2651-02
Quote ID: 082008-0000-0005

TERMS AND CONDITIONS OF SALE (Contract Sales)

1. **REMITTANCES** All invoices shall be due and payable upon receipt in United States currency, free of exchange, or any other charges, or as otherwise agreed upon and set forth in writing by Siemens Building Technologies, Inc. (hereinafter called "Seller"). The Customer, if so requested agrees to furnish Seller with all information including financial statements, necessary to make a proper credit appraisal. Refusal to supply information may cause this proposal to be withdrawn. Terms of payment originally granted are subject to the approval of continued credit status. Prices are subject to correction for error.
2. **PROPOSALS** Proposals are based upon straight-time labor. Any request by the Customer for overtime work shall be considered an extra. This proposal expires 60 days after its date, subject to the provisions of the first sentence of the paragraph below entitled "Acceptance of Terms."
3. **PROGRESS PAYMENTS** Seller reserves the right to invoice Customer monthly as the work progresses, for all materials delivered to the job site or to an off-site facility and for all work performed on-site and off-site. Engineering, drafting and other mobilization costs incurred prior to installation shall be included in Seller's initial invoice and be equal to fifteen percent (15%) of the contract price. Invoices are due upon receipt by Customer. If the Customer becomes overdue in any progress payment, Seller shall be entitled to suspend work, shall be entitled to interest at the annual rate of 18% or the maximum permitted by the State of Illinois; and also to avail itself of any other legal remedies. Seller shall also be entitled to interest on all amounts retained by Customer from progress payments or otherwise. Customer agrees that he will pay and/or reimburse Seller for any and all reasonable attorneys fees which are incurred by Seller in the collection of amounts due and payable hereunder.
4. **CANCELLATION AND SUSPENSION** Any contract resulting from this proposal is subject to cancellation or instructions to suspend work by the customer only upon agreement to pay Seller adjustment charge.
5. **TAXES** The amount of any future sales, use, occupancy, excise, or other tax, federal, state, or local which Seller hereafter shall be obligated legally to pay, either on its own behalf of the Customer or otherwise, with respect to the material covered by this proposal, shall be added to such prices and paid by the Customer.
6. **LOSS, DAMAGE OR DELAY** Seller shall not be liable for any loss, damage, or delay occasioned by any causes beyond Seller's control, including, but not limited to, governmental actions or orders, embargoes, strikes, differences with workmen, fires, floods, accidents, or transportation delays. **IN NO EVENT SHALL SELLER BE LIABLE FOR ANY CONSEQUENTIAL OR SPECIAL DAMAGES.**
7. **WARRANTY** Seller warrants that the equipment manufactured and services furnished by it and covered by this proposal are free from defects in material and workmanship under normal use and service and, without charge, equipment found to be so defective in material or workmanship will be repaired or replaced, if written notice of failure is received by Seller within one (1) year after date of installation, provided said equipment has been operated in accordance with Seller's instructions and provided such defects are not due to abuse, fire or decomposition by chemical or galvanic action. **THIS EXPRESS WARRANTY IS IN LIEU OF AND EXCLUDES ALL OTHER WARRANTIES, GUARANTEES, OR REPRESENTATIONS, EXPRESS OR IMPLIED. THERE ARE NO IMPLIED WARRANTIES OF MERCHANTABILITY OR OF FITNESS FOR A PARTICULAR PURPOSE.** Seller assumes no responsibility for repairs made on Seller's equipment unless done by Seller's authorized personnel, or by written authority from Seller. Seller makes no guarantee with respect to material not manufactured by it.
8. **PURCHASER'S REMEDIES** The Customer's remedies with respect to equipment found to be defective in material or workmanship shall be limited exclusively to the right of repair or replacement of such defective equipment. **IN NO EVENT SHALL SELLER BE LIABLE FOR CLAIMS (BASED UPON BREACH OF IMPLIED WARRANTY) FOR ANY OTHER DAMAGES, WHETHER DIRECT, IMMEDIATE, FORESEEABLE, CONSEQUENTIAL, OR SPECIAL OR FOR ANY EXPENSES INCURRED BY REASON OF THE USE OR MISUSE OF EQUIPMENT WHICH DOES OR DOES NOT CONFORM TO THE TERMS AND CONDITIONS OF ANY CONTRACT RESULTING FROM THIS PROPOSAL.**
9. **PATENT INFRINGEMENT** Seller will hold its Customer and the Owner harmless from infringement of any United States patent covering equipment of its manufacture. This, of necessity, is limited to the equipment per se and cannot be extended to applications of such equipment in a system, except in writing by an officer of Seller. The Customer and Owner shall advise Seller immediately in the event any claims of infringement are brought to their attention.
10. **GOVERNING LAW** Any contract resulting from this proposal shall be governed by, construed, and enforced in accordance with the laws of the State of Texas.
11. **CERTIFICATION** The person whose signature appears on the attached hereof hereby certifies that, to his best knowledge and belief, the annexed bid is not the result of any agreement, arrangement or understanding between the Seller and any other manufacturer or seller of automatic temperature control systems and that the prices, terms or conditions thereof have not been communicated by or on behalf of the Seller to any such person and will not be communicated to any such person prior to the official opening of said bid.
12. **ACCEPTANCE OF TERMS** This proposal shall become a binding contract between the Customer and Seller when accepted in writing by the Customer. Such acceptance shall be with mutual understanding that the terms and conditions of this proposal are a part thereof with the same effect as though signed by both parties named herein and shall prevail over any inconsistent provision of said order.



Pricing Summary Report

Siemens Contact James "Jim" Knight
 Contact Phone # 210-253-2732
 Estimate ID: 082008-00000-0005

Print Date: 10-01-2008
 Start Date:
 Comp Date:

Siemens Material Total	\$24,773.73	Sub Contractor Total	\$20,872.50	Warranty Total	\$722.90
Outside Material Total	\$656.37	Miscellaneous Project Total	\$30.87	Sales Tax Total	\$0.00
Labor Total	\$15,951.45	Freight Total	\$542.18	Total Price	\$63,550.00
Labor Credit	\$0.00				
Material Credit	\$0.00				

Siemens Material		Outside Material	Overhead 15% / Profit 10%	Price
Siemens Material List Price	\$67,872.97	Outside Material List Price		\$2,708.15
Less Discount @ 63.50%	\$43,099.24	Less Discount @ 75.76%		\$2,051.78
Discounted Price	\$24,773.73	Discounted Price		\$656.37
Material Escalation	\$0.00	Material Escalation		\$0.00
Use Tax	\$0.00	Use Tax		\$0.00
Siemens Material Total	\$24,773.73	Outside Material Total		\$656.37

Specialist Labor				Overhead 15% / Profit 10%				
	Rate	Hours	Price	Parking	Tolls	Mileage	Lodging	Meals / Perdiem
Base	\$87.00	74.810	\$6,508.47	\$0.00	\$0.00	\$0.00	\$0.00	\$0.00
Time and a half OT	\$110.49		\$0.00					
Shift OT	\$91.35		\$0.00					
Double OT	\$133.98		\$0.00					
Labor Escalation			\$0.00					
Total Specialist Perdiem & Travel Exp.								\$0.00
Total Specialist Labor								\$6,508.47

Project Management Labor				Overhead 15% / Profit 10%				
	Rate	Hours	Price	Parking	Tolls	Mileage	Lodging	Meals / Perdiem
Base	\$87.00	24.000	\$2,088.00	\$0.00	\$0.00	\$0.00	\$0.00	\$0.00
Labor Escalation			\$0.00					
Total PM Perdiem & Travel Exp.								\$0.00
Total Project Management Labor								\$2,088.00

Engineering Labor				Overhead 15% / Profit 10%				
	Rate	Hours	Price	Parking	Tolls	Mileage	Lodging	Meals / Perdiem
Base	\$87.00	84.540	\$7,354.98	\$0.00	\$0.00	\$0.00	\$0.00	\$0.00
Labor Escalation			\$0.00					
Total Engineering Perdiem & Travel Exp.								\$0.00
Total Engineering Labor								\$7,354.98

Mechanical Labor				Overhead 0% / Profit 0%				
	Rate	Hours	Price	Parking	Tolls	Mileage	Lodging	Meals / Perdiem
Base	\$124.80	0.000	\$0.00	\$0.00	\$0.00	\$0.00	\$0.00	\$0.00
Time and a half OT	\$116.63		\$0.00					
Shift OT	\$133.98		\$0.00					
Double OT	\$141.42		\$0.00					
Labor Escalation			\$0.00					
Total Mechanic Perdiem & Travel Exp.								\$0.00
Total Mechanical Labor								\$0.00

Electrician Labor				Overhead 0% / Profit 0%				
	Rate	Hours	Price	Parking	Tolls	Mileage	Lodging	Meals / Perdiem
Base	\$120.00	0.000	\$0.00	\$0.00	\$0.00	\$0.00	\$0.00	\$0.00
Time and a half OT	\$85.94		\$0.00					
Shift OT	\$133.98		\$0.00					
Double OT	\$104.21		\$0.00					
Labor Escalation			\$0.00					
Total Electrician Perdiem & Travel Exp.								\$0.00
Total Electrician Labor								\$0.00

SIEMENS**Pricing Summary Report**

Print Date: 10-01-2008

Siemens Contact James "Jim" Knight

Start Date:

Contact Phone # 210-253-2732

Comp Date:

Estimate ID: 082008-00000-0005

Subcontractors		Overhead 15% / Profit 10%	Direct Project Costs		Overhead 15% / Profit 10%
Description	Price		Description	Price	
Wire & Conduit	\$20,872.50		Bond Fees	\$0.00	
			Large Tool Rental	\$0.00	
			Equipment Rental	\$0.00	
			Outside Services	\$0.00	
			Permits & Fees	\$0.00	
			Risks	\$0.00	
			Additional Clean-Up Costs	\$0.00	
			Additional Job Site Facilities costs	\$0.00	
			Exposed Contingencies	\$0.00	
			Extended Use of Tools and Rental	\$0.00	
			Trailer / Office Space	\$0.00	
			Utilities (Phones, Electric, Water, Sanitary, Supplies, etc.)	\$0.00	
			Additional Insurance Costs	\$30.87	
			Finance charges for delayed payment	\$0.00	
			Interest on Retention for Schedule extensions	\$0.00	
Total Sub Contractor		\$20,872.50	Total Direct Project Costs		\$30.87

SIEMENS**Material Summary Report**

Print Date: 10-01-2008

Siemens Contact James "Jim" Knight

Start Date:

Contact Phone # 210-253-2732

Comp Date:

Estimate ID: 082008-00000-0005

Page 1 of 2

Quantity	Part Number	Description	Unit Sell	Ext Sell Price
QFM Series RH Duct Sensor				
5	QFM3101	SENSOR (DUCT) RH: 4-20MA (HIGH QUALITY)	\$160.60	\$803.00
QFA Series 5% RH Room Sensors				
4	QFA2071.FBU	RM RHT 5%, MA, FF, BEG, SL	\$124.10	\$496.40
1000 Series MBC/RBC/MEC				
8	544-760A	ROOM SENSOR,DST BEIGE	\$39.47	\$315.76
Analog- 1000 Ohm Platinum RTD				
5	544-345	D/AV SNSR,48"PRB,RTD -40/240F	\$88.86	\$444.30
1	544-577	IMM TEMP SENS (-40/240F)	\$62.78	\$62.78
Setra Systems				
1	A7F30011219	DP TRAN WET UNI/BI 0-10/20/50/100P,MAN	\$436.43	\$436.43
Setras				
1	C264-5	DP TRANS AIR FLOW,1%,5.0 INCH	\$154.21	\$154.21
5	C264+/-0.25	DP TRAN AIR FLOW,1%,+/-0.25 IN	\$154.21	\$771.05
QPA Series CO / VOC				
5	QPA63.2	IAQ CO2/VOC SENSOR W/LED DISPL	\$313.17	\$1,565.85
QPA Series CO / VOC Accessories				
5	ARG64	CO2 SENSOR DUCT MOUNTING KIT	\$128.95	\$644.75
Low Temperature Detection				
5	134-1510	LOW TEMP DET STATAUTO RESET	\$72.73	\$363.65
SW 141 Series Differential Static				
1	141-0518	AIR FLOW SWITCH	\$38.12	\$38.12
PXC Modular Controller				
1	PXC100-PE96.A	PXC Modular Controller w/P2 ALN /96 FLN Devices	\$2,534.56	\$2,534.56
1	PXX-485.3	Triple RS-485 Expansion Module	\$324.44	\$324.44
Accessories & Service Kits				
5	PXA-ENC19	ENCLOSURE ASSY 19"	\$233.19	\$1,165.95
5	549-506	SERVICE BOX,MEC,115V	\$202.78	\$1,013.90
1	TXA1.LH	Module Label Holder	\$5.31	\$5.31
1	TXA1.K24	Address Keys 1-24	\$9.13	\$9.13
8	540-147	TERM EQPT CTLR EX RELAY MODULE	\$117.90	\$943.20
8	588-100B	6-wire w/RJ11 RS cbl 50' Plnm	\$10.22	\$81.76

PXC Compact Series Controllers

SIEMENS**Material Summary Report**

Print Date: 10-01-2008

Siemens Contact James "Jim" Knight

Start Date:

Contact Phone # 210-253-2732

Comp Date:

Estimate ID: 082008-00000-0005

Page 2 of 2

Quantity	Part Number	Description	Unit Sell	Ext Sell Price
4	PXC24-P.A	PXC COMPACT 24-PT, P2 RS-485, APOGEE	\$942.92	\$3,771.68
TX/IO Modules				
1	TXS1.12F4	24VDC SUPPLY 1200MA, 4 A FUSE	\$178.85	\$178.85
3	TXM1.8X-ML	8Unlv w/4-20mA w/OVD	\$539.29	\$1,617.87
Functional Devices				
24	RIBU2C	RIB 120VAC 24VAC/DC 2SPDT	\$20.18	\$484.32
VERIS INDUSTRIES				
7	H908	CURRENT SW SPLITCORE-ADJ W/LED	\$31.42	\$219.94
OpenAir GCA Series				
7	GCA161.1P	MOD(V) SR,24V, MED. PLNM	\$178.90	\$1,252.30
Terminal Equipment Controllers				
8	540-100	TERM BOX CTRLR ELEC OUT	\$231.41	\$1,851.28
OpenAir GDE Series				
8	GDE131.1P	ACT NSR PLENUM 24/108L 5Nm	\$48.79	\$390.32
TEC - 1000 Series				
8	540-662A	TEC RM SNSR-W/OVRD,BEIGE	\$37.60	\$300.80
Analog- 100K Ohm Thermistor				
8	536-811	100K OHM DUCT TEMP SENSOR	\$16.83	\$134.64
274-XXXXX 3 Way w/SKD62U				
5	274-03205	3WMX BZ =% OR FXF 1.50/25.00	\$610.71	\$3,053.55

Cost Savings Calculations

Summary	RGV Contractor Credit	Owner Procured
Environmental Management System	\$74,050	\$63,550
Food Service Equipment	\$63,747	\$77,000
Playground Equipment	\$181,860	\$64,470
Total	\$319,657	\$205,020

TOTAL SAVINGS

\$114,637



TEXAS SOUTHMOST COLLEGE DISTRICT

BOARD AGENDA REQUEST FORM

Department/Division: Office for Planning and Construction Office/ Partnership Affairs	Board Meeting Date: October 30, 2008
Agenda Item: Consideration and possible action on food services equipment purchase for the Center for Early Childhood Studies.	
Rationale/Background: Owner procurement of materials was identified as one of the cost control strategies for the bond projects. Food service equipment and Playground equipment for the Center for Early Childhood Studies were identified as two of the items that could provide substantial savings for the project. A request for proposals for food service equipment was issued according to Texas Southmost College Board policies for purchasing and bids. One response was received September 17, 2008 from Kitchen Resources, L.P. Upon evaluation of the proposal, the respondent, Kitchen Resources, L.P., met all the requirements as per the specifications and is qualified to provide food service equipment. The attached proposal in the amount of \$77,000 includes a detailed description of the items to be purchased. Owner procured items for the Center for Early Childhood Studies represent a total savings of \$114,000 to the project.	
Recommended Action: Motion to accept proposal from Kitchen Resources, L.P. in the amount of \$77,000.00 and authorize the Assistant Vice President for Planning and Construction to execute the contract.	
Fiscal Implications: Budgeted Item: <input checked="" type="checkbox"/> Yes <input type="checkbox"/> No <input type="checkbox"/> N/A If no, explain:	
Attachments (List): 1. Bid Tabulation 2. Recommended Proposal 3. Cost Savings Calculations	

FOR OFFICE USE ONLY:
Board Action: Approved: <input type="checkbox"/> Yes <input type="checkbox"/> No <input type="checkbox"/> N/A <input type="checkbox"/> Tabled for action on: _____
Certified by: _____ Title: _____ Date: _____

Texas Southmost College District

Bid TSC B09-01

Center for Early Childhood Studies - Food Services Equipment

Bid Opening: Wednesday, September 17, 2008 at 4:00 p.m.

Cueto Conference Room

	Bidders Name	Bond (Y/N)	Addendum 1 Received	Base Bid
1	Kitchen Resources L.P.	Y	Y	\$77,000



To: Ms. Veronica Mendez
Assistant VP for Planning and Construction

From: Ms. Diana Bravo Gonzalez
Bond Project Manager/Architect

Date: October 6, 2008

Subject: Purchase of Food Services Equipment

Project: Center for Early Childhood Studies

Please accept this letter of recommendation to purchase food services equipment for the Center for Early Childhood Studies from Kitchen Resources, L.P. of Harlingen, Texas.

The bid document was prepared by the Office for Planning and Construction. The bid document called for a list of general bidding requirements, specifications and drawings for the food services equipment requirements and scope of work. Specifications and Drawings are part of the set of Construction Documents prepared by the architect Larry Janousek for the Center for Early Childhood Studies.

The Office for Planning and Construction solicited bids from qualified companies in accordance to TSC procurement policy. Advertisements were published on Wednesday, August 13, and Wednesday 20, 2008. Proposals were received on September 17, 2008.

Several potential bidders were contacted and encouraged to submit proposals. Nevertheless, only one proposal was received from Kitchen Resources, L.P. This proposal has been carefully reviewed and evaluated by Mr. Larry Janousek and myself. We have checked inclusion of all equipment, scope of work and requested material.

Based on the review of the proposal received, it is my recommendation to purchase the Food Services equipment for the Center for Early Childhood Studies from **Kitchen Resources, L.P** from Harlingen, Texas in the amount of \$77,000.

In comparison to the credit received from RGV Paint Center and Construction for the environmental energy management system, playground equipment and food service equipment, the recommended bids represent a savings of about \$114,000.

Quote



9/19/2008

Project:

UTB Center for Early Childhood
Studies

From:

Kitchen Resources, L.P.
Elva Villarreal
806 W. Harrison
Harlingen, TX 78550
Phone: (956) 423-2491
Fax: (956) 423-3088
Email:
elva@kitchenresources.com

Item	Qty	Description	Sell Each	Sell Total
101	1	ea FREEZER, REACH-IN  Traulsen Model No. ALT132WUT-HHS Class: 110 Freezer, Reach-in, One-Section, Self-Contained Refrig System, stainless steel exterior, aluminum interior, standard depth cabinet, half-height doors, with INTELA-TRAUL™, ENERGY STAR® 1 ea 0 degrees F holding temperature, std. 1 ea 115v/60/1ph, w/cord & plug attached, std. 1 ea 1 yr service/labor, 5 yr compressor & 2 yr control warranty (std.) 1 ea Door hinged on right, std. 7 ea Universal tray slide - per pair Weight: 455 lbs. total	6,308.55	6,308.55
102	1	ea REFRIGERATOR, REACH-IN  Traulsen Model No. AHT232NUT-HHS Class: 110 Refrigerator, Reach-in, Two-Section, Self-Contained Refrig System, stainless steel exterior, aluminum interior, standard depth cabinet, half-height doors, with INTELA-TRAUL™ 1 ea 115v/60/1ph, w/cord & plug attached, std. 1 ea 1 yr service/labor, 5 yr compressor & 2 yr control warranty (std.) 1 ea Door hinging to be determined 14 ea Universal tray slide - per pair Weight: 625 lbs. total	7,401.05	7,401.05
103	1	ea CUSTOM Casteel Mfg., Inc. Model No. CUSTFAB Mobile Plating Table 4'-0" X 2'-6"	1,406.12	1,406.12
104	1	ea CUSTOM Casteel Mfg., Inc. Model No. CUSTFAB Work Table W/Pot Rack	2,844.03	2,844.03
105	1	ea DISHWASHER, UNDERCOUNTER  Hobart Model No. LXIH-4 Undercounter Dishwasher, Hot Water Sanitation, 30 Racks/Hour, Fresh Water Rinse, Delime Notification, Service Diagnostics, With 70 Deg. Booster Heater & Pump Capability, Detergent & Rinse Aid Pumps, 120/208 -240(3W)/60/1 1 ea 1-Year parts, labor & travel time during normal working hours 1 ea PRESREG-1/20BR 1/2" brass pressure regulator 3 ea DISHRAK-PEG20 Peg rack	5,953.04	5,953.04

Weight: 278 lbs. total

106	1	ea	CUSTOM Casteel Mfg., Inc. Model No. CUSTFAB Dishable /Pot sink assembly	8,748.53	8,748.53
106.1	3	ea	CUSTOM Casteel Mfg., Inc. Model No. CUSTFAB 19" X 27"	183.41	550.23
106.2	1	ea	FAUCET T & S Brass Model No. B-0231-EE Class: 77.5 Sink Mixing Faucet, with 12" swing nozzle, wall mounted, 8" centers on sink faucet with 1/2" IPS EE male inlets with adjustable flange, lever handles	506.55	506.55



Weight: 5.31 lbs. total

106.8	3	ea	CUSTOM Casteel Mfg., Inc. Model No. CUSTFAB 19" X 27"	183.41	550.23
106.9	1	ea	CUSTOM Casteel Mfg., Inc. Model No. CUSTFAB 3 S/S storage shelves	91.71	91.71
107	1	ea	DISPOSER InSinkErator Model No. SS-100-5-MRS Class: UPS Complete Disposer Package, sink mount system, with #5 adaptor for 3.5" to 4" sink opening, 1 HP motor, s/s construction, includes syphon breaker, solenoid valve, flow control valve, manual reverse switch	1,722.80	1,722.80



- 1 ea 1 yr. parts & labor warranty from date of installation (std)
- 1 ea Voltage to be determined later
- 1 ea DEJAMWRENCH Dejamming wrench, fits 6-5/8" opening only (Not for use with throat guard)

Weight: 66 lbs. total

107.4	1	ea	VACUUM BREAKER ASSEMBLY T & S Brass Model No. B-0456 Class: 77.5 Vacuum Breaker Unit, 1/2 IPS piping, slip flanges for mounting on flat surface, 6" between piping	219.32	219.32
-------	---	----	---	--------	--------



Weight: 3.86 lbs. total

108	1	ea	TOASTER, ELECTRIC CONVEYOR TYPE Hatco Model No. TQ-400H Class: 100 Toast-Qwik® Conveyor Toaster, horizontal conveyor, countertop design, all bread types toaster, approximately 6 slice capacity/min, electronic controls, colorguard sensing system, 2.2 kw	1,185.14	1,185.14
-----	---	----	---	----------	----------



- 1 ea NOTE: Includes 24/7 parts & service assistance, call 800-558-0607
- 1 ea 208v, 60Hz, 1-ph, NEMA 6-15P
- 1 ea TQRAMP Extended Feed Guide, (add 3") in lieu of standard feed guide
- 1 ea TQ-PWR-A Automatic Power Save Mode (switches to power save mode after 30 minutes of inactivity)

Weight: 48 lbs. total

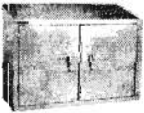

109	1	ea	MICROWAVE OVEN Amana Commercial Products Model No. RCS10MPA Class: UPS Packed: each Commercial Microwave Oven, 1000 watts, 10 programmable timing pads, 5 power levels, braille touch pads, removable air filter, side hinged door, limited 3-yr warranty, 15 amp, 120V, 60Hz, NEMA 5-15	600.50	600.50
			Weight: 56 lbs. total		
110	2	ea	FOOD CARRIER, INSULATED PLASTIC Cambro Model No. UPC400-110 Packed: each Camcarrier® Ultra Pancarrier®, front loading, one-piece poly shell, foam insul., holds 1/2, 1/3 & full size pans 2-1/2" to 8" deep, approximately cap. 60 qt., molded-in handles, nylon latch, air-tight gasket, vent cap, stackable, black, NSF	698.46	1,396.92
	2	ea	CD400-110 Camdolly®, 20-3/4"D x 27-5/8"L x 9"H, load capacity 300 lbs., black, NSF		
	2	ea	CP1220-159 Camchiller®, Full Size GN, maintains chilled foods in transport, 20-13/16"L x 12-7/8"W x 1-1/2"H, cold blue, dishwasher safe, NSF		
	2	ea	1210PW-191 Camwarmer, heat retentive pellet enclosed within a heat resistant top & bottom tray, for use in various Camcarriers, Camcarts and Combo Carts, granite gray, NSF		
			Weight: 129 lbs. total Cube: 21.58		
111	1	ea	ICE MAKER, CUBE-STYLE Manitowoc Model No. SD-0452A Class: 92.5 Packed: each S-Series Ice Maker, cube-style, air-cooled, self-contained condenser, up to 450-lb approximately/24 hours, stainless steel finish, dice size cubes	3,521.40	3,521.40
	1	ea	3 year parts & labor warranty		
	1	ea	5 year parts & labor warranty on evaporator		
	1	ea	5- year parts & 3- year labor warranty on compressor		
	1	ea	115v/60/1ph, std.		
	1	ea	B-400 Ice Bin, w/top-hinged front-opening door, approximately 290 lb ice storage capacity, for top-mounted ice maker, stainless steel exterior		
	1	ea	6" adjustable stainless steel legs, std.		
	1	ea	AR-PRE Arctic Pure® Pre-Filter Assembly, 5 micron filtration (NOT stand-alone; should be used in conjunction with primary water filter assembly)		
	1	ea	AR-10000 Arctic Pure® Primary Water Filter Assembly, includes head, shroud, hardware, mounting assembly, and one filter cartridge, 14,000 gallon capacity, 0-600 lbs./ice per day		
			Weight: 268.667 lbs. total		
112	15	ea	SHELVING, WIRE AMCO Corp. Model No. A2448CP Class: 70 Amco II® Shelf, wire, 24" wide, 48" long, chrome plated finish	134.59	2,018.85
	1	ea	A2430CP Amco II® Shelf, wire, 24" wide, 30" long, chrome plated finish		
	1	ea	P84CP Amco II® Post, 84" high, for use without stem casters, chrome plated		
	1	ea	AOCLIPZP Shelving Clip Add-On, zinc protoxy		
			Weight: 295 lbs. total		

113	1	ea	SINK, HAND Advance Tabco Model No. 7-PS-50 Class: 100 Hand Sink, wall model, 14" wide x 10" front-to-back x 5" deep bowl, 20 gauge stainless steel construction, with splash mounted faucet, lever drain w/overflow, P-trap, wall bracket	589.12	589.12
	1	ea	K-316-LU Wrist Handle Only, for splash mounted sinks		
	1	ea	7-PS-27 Bolted Side Splash, 7-3/4" tall, in-field installation (hardware not included), for hand sinks with 10"x14" bowls & splash mounted faucets		
	1	ea	7-PS-35 Paper Towel Dispenser-Wall Mounted		
	1	ea	7-PS-12 Soap Dispenser, wall mounted		
			Weight: 25 lbs. total Cube: 2		
114	1	ea	CUSTOM Casteel Mfg., Inc. Model No. CUSTFAB Prep Table W/sink	2,449.10	2,449.10
114.5	1	ea	FAUCET T & S Brass Model No. B-0221-EE Class: 77.5 Deck Mixing Faucet, with swing nozzle, 12" swing nozzle, 8" centers on deck faucet with 1/2" IPS EE male inlets with adjustable flange, lever handles	178.40	178.40
			Weight: 4.891 lbs. total		
114.8	1	ea	CUSTOM Casteel Mfg., Inc. Model No. CUSTFAB Richlite	190.00	190.00
115	1	ea	VENT HOOD Caddy Model No. PB-C-W-ASI-72-ND-66 Long Baffle Filter Type	7,003.98	7,003.98
116	1	ea	RANGE, 60" RESTAURANT, GAS Garland/US Range Model No. G60-10RR G Starfire Pro Series Restaurant Range, gas, 60"W, (10) 33,000 BTU open burners, with cast iron top & ring grates, (2) standard ovens w/3 position rack guides w/oven rack each, s/s front, sides, plate rail, backguard, & high shelf, 6" s/s legs with adjustable feet, 406,000 BTU	8,511.37	8,511.37
	1	ea	One year limited parts and labor warranty (USA & Canada only), std		
	1	ea	Natural gas, specify elevation if over 2,000 ft		
	1	ea	One Convection Oven add suffix -RC standard on right unless specified left (Full-Size Oven)		
	2	ea	4522408 Extra oven rack, for stand ovens		
	1	ea	6" s/s legs with adjustable feet, std.		
	1	ea	CUST 24" Thermostat griddle add suffix - 24th to modle No (ea. 12" of griddle replaces 2 burners) standardk on right		
			Weight: 736 lbs. total Cube: 79		
116.8	1	ea	SAFETY SYSTEM MOVEABLE GAS CONNECTOR Dormont Manufacturing Model No. 1675KITCF2S48 Safety System Moveable Gas Connector Kit, 3/4" inside dia., 48" long covered with stainless steel braid, coated with blue antimicrobial PVC, 1 Safety Quik QDV, 2 SwivelMAX™, and coiled restraining cable with hardware, limited lifetime warranty	343.00	343.00
			Weight: 6.6 lbs. total		

117	1	ea	FIRE PROTECTION Argus Security Systems, Inc. Model No. R-102 Fire Protection	3,547.50	3,547.50
118	1	ea	AIR CURTAIN Mars Air Doors Model No. 36CH Class: 110 Packed: each Air Curtain, CH Model, Unheated, high-impact white PolyMars® housing, 36" long, for doors 8 to 10-feet high, 1/2 HP motor 1 ea 115v, 60 hz, 1-ph, 5.1 FLA, std. 1 ea TZ6112 Combination Plunger/Roller Micro Switch, for instant on/off control, use on any type of door Weight: 51 lbs. total	1,551.10	1,551.10
119	1	ea	UTILITY CART Lakeside Manufacturing Model No. 511 Class: 125 Packed: each Utility Cart, open, 3 shelf, shelf size 15-1/2" x 24", stainless steel frame w/push handle, 700 lb. capacity, (2) 5" swivel and (2) 8" fixed casters, NSF  1 ea Casters, 5" 2 with brakes Weight: 57 lbs. total Cube: 14.3	825.10	825.10
120	1	ea	CUSTOM Casteel Mfg., Inc. Model No. CUSTFAB Work Counter 8'-0" X 2'-6"	1,717.91	1,717.91
121	1	ea	CABINET, WALL-MOUNTED Eagle Group Model No. WCH-36 Class: 100 Packed: each Cabinet, Wall-Mounted, enclosed design with hinged doors, 36"L with single intermediate shelf, stainless steel construction  Weight: 125 lbs. total Cube: 14.5	1,962.76	1,962.76
122	1	ea	CAN OPENER, MANUAL Edlund Model No. 1 Packed: 3 pieces Can Opener, Manual, #1 with plated base (for cans up to 11" tall), "Old Reliable"  1 ea 1 yr. limited warranty, std. 1 ea ST-93 Rustproof Can Opener Cleaning Tool, stainless steel bristles and stainless scraper Weight: 9.167 lbs. total Cube: 0.467	240.65	240.65
123	1	ea	CUSTOM Casteel Mfg., Inc. Model No. CUSTFAB S/S Wall Panels	2,429.95	2,429.95
124	1	ea	BUN PAN RACK, MOBILE New Age Model No. 1311 Class: 250 Packed: each Pan Rack, mobile, 1/2 size height, open sides, with slides for 18"x26" pans, slides on 3" centers, all welded aluminum construction, end loading, stainless steel top, (4) 5" stem swivel casters, NSF  1 ea Lifetime warranty against rust & corrosion, 5 year construction warranty, std. 1 ea CL-A Caster Lock, for 5" stem caster (pair)	434.99	434.99

Weight: 44 lbs. total Cube: 11.4

Merchandise	77,000.00
Total	77,000.00

Manufacturer Summary

MFR	FOB	ZIP	Class	Weight	Good Until	Terms
	Factory				10/18/2008	
Advance	Factory	11717	Total	25	10/18/2008	
Amana	Factory	52404	UPS	56	10/18/2008	
Amco	Factory	60614	70	295	10/18/2008	
ARGUS	Factory	78501			10/18/2008	
Caddy	Factory	08014			10/18/2008	
Cambro	Factory	92647		129	10/18/2008	
CASTEEL	Factory	78211			10/18/2008	
Dormont	Factory	15632		6.6	10/18/2008	
Eagle	Factory	19938	100	125	10/18/2008	
Edlund	Factory	05401		9.167	10/18/2008	
GARUSR	Factory	18224		736	10/18/2008	
Hatco	Factory	53215	100	48	10/18/2008	
Hobart	Destination	45374		278	10/18/2008	
InSink	Destination	53406	UPS	66	10/18/2008	
Lakeside	Factory	53219	125	57	10/18/2008	
Manitowc	Destination	54221	Total	268.667	10/18/2008	
Mars	Factory	90248	110	51	10/18/2008	
NewAge	Factory	67654	250	44	10/18/2008	
T&S	Factory	29690	77.5	14.061	10/18/2008	
Traulsen	Factory	76106	110	1080	10/18/2008	

Thank You for the Opportunity to Quote

Acceptance: _____ Date: _____

Printed Name: _____

Cost Savings Calculations

Summary	RGV Contractor Credit	Owner Procured
Environmental Management System	\$74,050	\$63,550
Food Service Equipment	\$63,747	\$77,000
Playground Equipment	\$181,860	\$64,470
Total	\$319,657	\$205,020

TOTAL SAVINGS

\$114,637



TEXAS SOUTHMOST COLLEGE DISTRICT

BOARD AGENDA REQUEST FORM

Department/Division: Office for Planning and Construction Office/ Partnership Affairs	Board Meeting Date: October 30, 2008
Agenda Item: Consideration and possible action on playground equipment purchase for the Center for Early Childhood Studies.	
Rationale/Background: Owner procurement of materials was identified as one of the cost control strategies for the bond projects. Food service equipment and Playground equipment for the Center for Early Childhood Studies were identified as two of the items that could provide substantial savings for the project. A request for proposals for playground equipment was issued according to Texas Southmost College Board policies for purchasing and bids. Three Responses were received on September 17, 2008. Upon evaluation of the proposals, Creative Components was selected as the best value respondent to supply the playground equipment in the amount of \$64,470. The attached proposal includes a detailed description of the items to be purchased. Owner procured items for the Center for Early Childhood Studies represent a total savings of \$114,000 to the project.	
Recommended Action: Motion to accept proposal from Creative Components in the amount of \$64,470 and authorize the Assistant Vice President for Planning and Construction to execute the contract.	
Fiscal Implications: Budgeted Item: <input checked="" type="checkbox"/> Yes <input type="checkbox"/> No <input type="checkbox"/> N/A If no, explain:	
Attachments (List): 1. Bid Tabulation 2. Recommended Proposal 3. Cost Savings Calculations	

FOR OFFICE USE ONLY:
Board Action: Approved: <input type="checkbox"/> Yes <input type="checkbox"/> No <input type="checkbox"/> N/A <input type="checkbox"/> Tabled for action on: _____
Certified by: _____ Title: _____ Date: _____

Texas Southmost College District

Bid TSC B09-02

Center for Early Childhood Studies - Playground Equipment

Bid Opening: Wednesday, September 17, 2008 at 4:30 p.m.

Cueto Conference Room

	Bidders Name	Bond (Y/N)	Addendum 1 and 2 Received	Base Bid
1	Park Place Recreation Design	Y	Y	\$74,588
2	Creative Components	Y	Y	\$64,470
3	Exerplay, Inc.	Y	Y	\$73,201.46
4	PlayWell Group	Y	Y	\$65,912.52



To: Ms. Veronica Mendez
Assistant VP for Planning and Construction

From: Ms. Diana Bravo Gonzalez
Bond Project Manager/Architect

Date: October 6, 2008

Subject: Purchase of Playground Equipment

Project: Center for Early Childhood Studies

Please accept this letter of recommendation to purchase playground equipment for the Center for Early Childhood Studies from Creative Components of Wimberley, Texas.

A bid package was prepared by the Office for Planning and Construction. The bid package called for a list of general bidding requirements, specifications and drawings and scope of work for the playground equipment. Specifications and Drawings for the playground equipment were prepared by the architect Larry Janousek for the Center for Early Childhood Studies.

The Office for Planning and Construction solicited bids from qualified companies in accordance to TSC procurement policy. Advertisements were published on Wednesday, August 13, and Wednesday 20, 2008. Proposals were received on September 17, 2008.

Responses were received from the following companies:

- Park Place Recreation Design
- Creative Components
- ExerPlay, Inc.
- Playwell Group

Proposals have been carefully reviewed and evaluated by Mr. Larry Janousek and myself. We have checked inclusion of all equipment, scope of work and requested material. Based on the evaluation results, we determined that Creative Components is the best qualified respondent to this bid.

It is my recommendation to purchase the Playground equipment for the Center for Early Childhood Studies from Creative Components from Wimberley, Texas in the amount of \$64,470.

In comparison to the credit received from RGV Paint Center and Construction for the environmental energy management system, playground equipment and food service equipment, the recommended bids represent a savings of about \$114,000.

Creative Components

Playground and Park Equipment, Shade Canopies
Designs, Sales and Installation

Proposal # 809154

Date: 09/15/08

Organization: Texas Southmost College

Phone: 956 882-4311

Contact Name: Patricia G. Sanchez

Fax: 956 882-4316

Address: 1301 E. Madison Street

E-mail: patricia.sanchez@utb.edu

Brownsville, Tx 78520

Representative: Darrell Lawson

This quote is valid for 30 days .

Project Name: *Playground Equipment for Center for Early Childhood Studies*

Quantity	Description	Amount
1	P-1 Spring See Saw PC 1920 (<i>approved equal for 'Daisy'</i>)	\$2,149.00
1	P-2 Playstructure PR# BFE18A (<i>approved equal for 'Pirate Ship'</i>)	\$18,634.00
1	P-3 Playstructure PR#6E357A (<i>approved equal for 'Explorer'</i>)	\$2,802.00
1	P-4 8x8' Sand Box with Table (SBX-00002 & SBX-00003)	\$960.00
2	P-5 Paint Stations (PC 1580-G)	\$1,450.00
2	P-6 Children's Tables (T6RC-ELEM)	\$1,100.00
1	P-7 Playstructure PR# E5545A (<i>approved equal for 'Cottage'</i>)	\$3,100.00
1	S-1 Single Post Umbrella Canopy 12' x 12'	\$3,500.00
10 Supersacks	Rubber Mulch	\$8,935.00
40 tons	Gravel	\$1,000.00
3 cu yds	Sand	\$100.00
	Geotextile Fabric	\$400.00
	Shipping	\$3,680.00
	Approx. 550 sq. ft. EPDM Rubber Surfacing (3/8" thickness)	\$6,740.00
	Installation Of Above Items	<u>\$9,920.00</u>
	Total	\$64,470.00

Thank you, we appreciate your business!

Accepted By: _____

Darrell Lawson
Creative Components

Title: _____

Please send payments and inquires to:

Date: _____

Creative Components
1080 Peale Rd
Wimberley, TX 78676
Phone: (888) 370-6532
Fax: (830) 935-4090

1. Payment of 50% due with order, remainder due upon completion.
2. Customer is responsible for locating underground utilities.
3. Price is based on easy accessibility to site for trucks and loader.

FORT BROWN RESACA

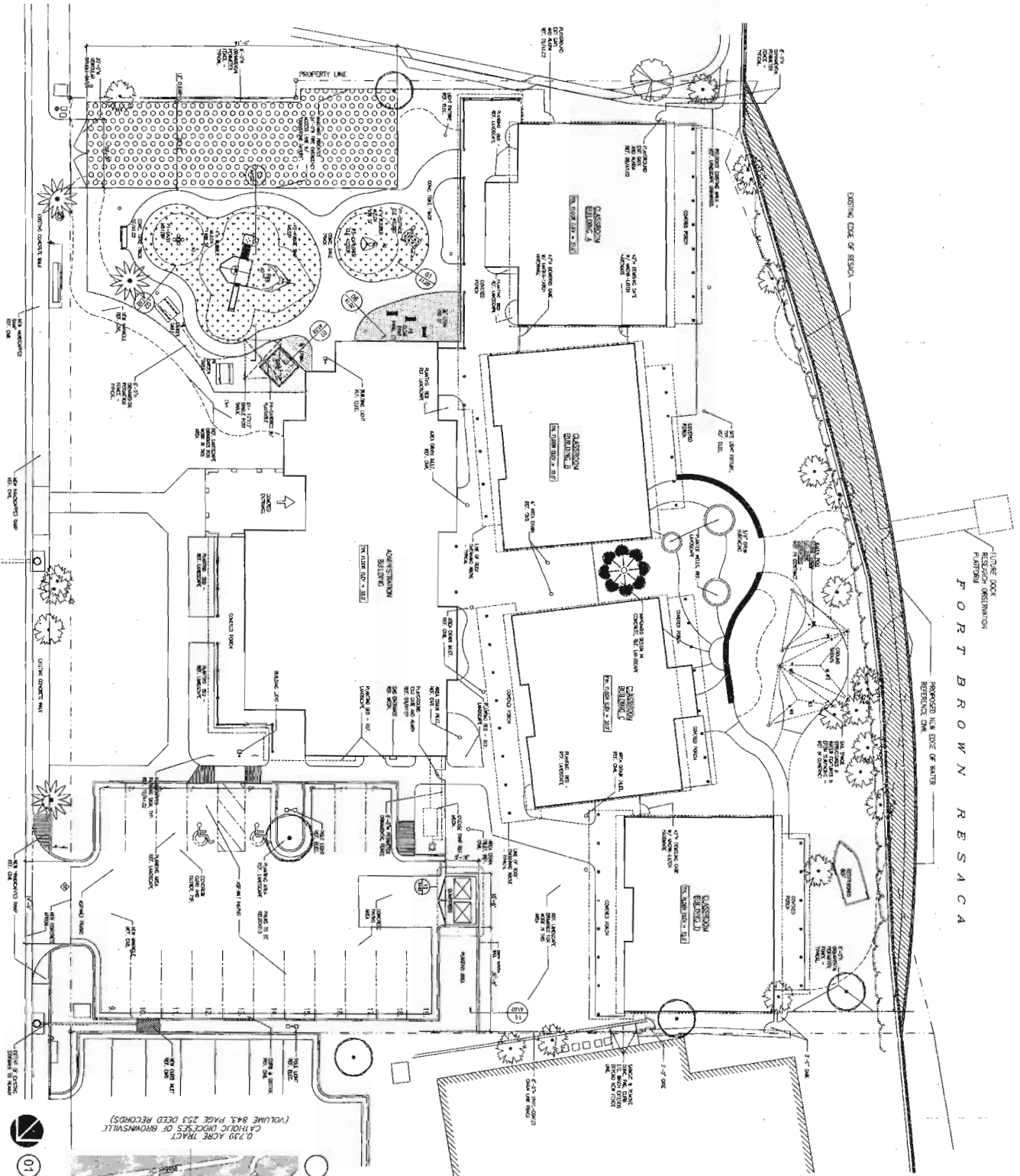

PLAY EQUIPMENT

NO.	DESCRIPTION	QUANTITY	MANUFACTURER
1	MONITORING STATION	1	WELLS
2	SHADE	1	WELLS
3	SLIP RESISTANT	1	WELLS
4	SLIP RESISTANT	1	WELLS
5	SLIP RESISTANT	1	WELLS
6	SLIP RESISTANT	1	WELLS
7	SLIP RESISTANT	1	WELLS
8	SLIP RESISTANT	1	WELLS
9	SLIP RESISTANT	1	WELLS
10	SLIP RESISTANT	1	WELLS
11	SLIP RESISTANT	1	WELLS
12	SLIP RESISTANT	1	WELLS
13	SLIP RESISTANT	1	WELLS
14	SLIP RESISTANT	1	WELLS
15	SLIP RESISTANT	1	WELLS
16	SLIP RESISTANT	1	WELLS
17	SLIP RESISTANT	1	WELLS
18	SLIP RESISTANT	1	WELLS
19	SLIP RESISTANT	1	WELLS
20	SLIP RESISTANT	1	WELLS
21	SLIP RESISTANT	1	WELLS
22	SLIP RESISTANT	1	WELLS
23	SLIP RESISTANT	1	WELLS
24	SLIP RESISTANT	1	WELLS
25	SLIP RESISTANT	1	WELLS
26	SLIP RESISTANT	1	WELLS
27	SLIP RESISTANT	1	WELLS
28	SLIP RESISTANT	1	WELLS
29	SLIP RESISTANT	1	WELLS
30	SLIP RESISTANT	1	WELLS
31	SLIP RESISTANT	1	WELLS
32	SLIP RESISTANT	1	WELLS
33	SLIP RESISTANT	1	WELLS
34	SLIP RESISTANT	1	WELLS
35	SLIP RESISTANT	1	WELLS
36	SLIP RESISTANT	1	WELLS
37	SLIP RESISTANT	1	WELLS
38	SLIP RESISTANT	1	WELLS
39	SLIP RESISTANT	1	WELLS
40	SLIP RESISTANT	1	WELLS
41	SLIP RESISTANT	1	WELLS
42	SLIP RESISTANT	1	WELLS
43	SLIP RESISTANT	1	WELLS
44	SLIP RESISTANT	1	WELLS
45	SLIP RESISTANT	1	WELLS
46	SLIP RESISTANT	1	WELLS
47	SLIP RESISTANT	1	WELLS
48	SLIP RESISTANT	1	WELLS
49	SLIP RESISTANT	1	WELLS
50	SLIP RESISTANT	1	WELLS
51	SLIP RESISTANT	1	WELLS
52	SLIP RESISTANT	1	WELLS
53	SLIP RESISTANT	1	WELLS
54	SLIP RESISTANT	1	WELLS
55	SLIP RESISTANT	1	WELLS
56	SLIP RESISTANT	1	WELLS
57	SLIP RESISTANT	1	WELLS
58	SLIP RESISTANT	1	WELLS
59	SLIP RESISTANT	1	WELLS
60	SLIP RESISTANT	1	WELLS
61	SLIP RESISTANT	1	WELLS
62	SLIP RESISTANT	1	WELLS
63	SLIP RESISTANT	1	WELLS
64	SLIP RESISTANT	1	WELLS
65	SLIP RESISTANT	1	WELLS
66	SLIP RESISTANT	1	WELLS
67	SLIP RESISTANT	1	WELLS
68	SLIP RESISTANT	1	WELLS
69	SLIP RESISTANT	1	WELLS
70	SLIP RESISTANT	1	WELLS
71	SLIP RESISTANT	1	WELLS
72	SLIP RESISTANT	1	WELLS
73	SLIP RESISTANT	1	WELLS
74	SLIP RESISTANT	1	WELLS
75	SLIP RESISTANT	1	WELLS
76	SLIP RESISTANT	1	WELLS
77	SLIP RESISTANT	1	WELLS
78	SLIP RESISTANT	1	WELLS
79	SLIP RESISTANT	1	WELLS
80	SLIP RESISTANT	1	WELLS
81	SLIP RESISTANT	1	WELLS
82	SLIP RESISTANT	1	WELLS
83	SLIP RESISTANT	1	WELLS
84	SLIP RESISTANT	1	WELLS
85	SLIP RESISTANT	1	WELLS
86	SLIP RESISTANT	1	WELLS
87	SLIP RESISTANT	1	WELLS
88	SLIP RESISTANT	1	WELLS
89	SLIP RESISTANT	1	WELLS
90	SLIP RESISTANT	1	WELLS
91	SLIP RESISTANT	1	WELLS
92	SLIP RESISTANT	1	WELLS
93	SLIP RESISTANT	1	WELLS
94	SLIP RESISTANT	1	WELLS
95	SLIP RESISTANT	1	WELLS
96	SLIP RESISTANT	1	WELLS
97	SLIP RESISTANT	1	WELLS
98	SLIP RESISTANT	1	WELLS
99	SLIP RESISTANT	1	WELLS
100	SLIP RESISTANT	1	WELLS

0.239 ACRE TRACT
CATHOLIC DIOCESE OF BROWNSVILLE
(VOLUME 843, PAGE 203 DEED RECORDS)

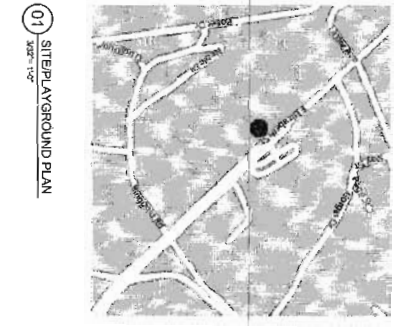

PLAYGROUND FEATURES

GENERAL NOTES:

1. ALL PLAYGROUND EQUIPMENT SHALL BE INSTALLED IN ACCORDANCE WITH THE LATEST EDITIONS OF THE CPSC AND ASTM STANDARDS.
2. ALL PLAYGROUND EQUIPMENT SHALL BE INSTALLED ON A SURFACE OF RUBBER MULCH OR OTHER SAFETY SURFACE.
3. ALL PLAYGROUND EQUIPMENT SHALL BE INSTALLED ON A SURFACE OF RUBBER MULCH OR OTHER SAFETY SURFACE.
4. ALL PLAYGROUND EQUIPMENT SHALL BE INSTALLED ON A SURFACE OF RUBBER MULCH OR OTHER SAFETY SURFACE.
5. ALL PLAYGROUND EQUIPMENT SHALL BE INSTALLED ON A SURFACE OF RUBBER MULCH OR OTHER SAFETY SURFACE.
6. ALL PLAYGROUND EQUIPMENT SHALL BE INSTALLED ON A SURFACE OF RUBBER MULCH OR OTHER SAFETY SURFACE.
7. ALL PLAYGROUND EQUIPMENT SHALL BE INSTALLED ON A SURFACE OF RUBBER MULCH OR OTHER SAFETY SURFACE.
8. ALL PLAYGROUND EQUIPMENT SHALL BE INSTALLED ON A SURFACE OF RUBBER MULCH OR OTHER SAFETY SURFACE.
9. ALL PLAYGROUND EQUIPMENT SHALL BE INSTALLED ON A SURFACE OF RUBBER MULCH OR OTHER SAFETY SURFACE.
10. ALL PLAYGROUND EQUIPMENT SHALL BE INSTALLED ON A SURFACE OF RUBBER MULCH OR OTHER SAFETY SURFACE.

STANDARD PC 1920 - SPRING SEESAW

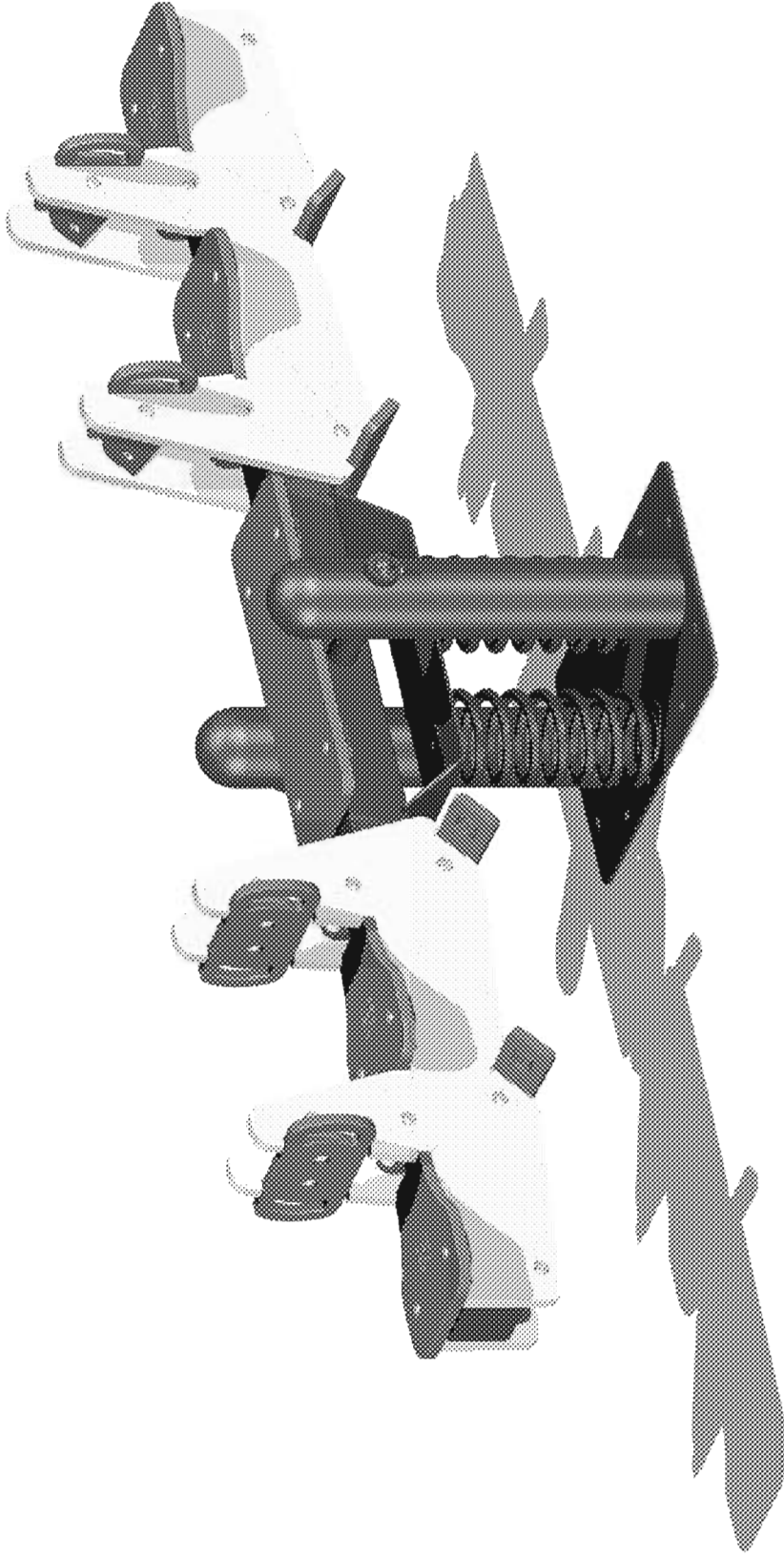

Date: 11/21/05
Drawn By: TC

SPRING SEESAW
Krauss Craft Inc.



123 NORTH VALLEY DRIVE
GRANTS PASS, OR 97526
PH: 541-955-9199
FAX: 541-955-6130

CUSTOM ROUND 3.5 MODULAR PLAYSYSTEM

Front Perspective

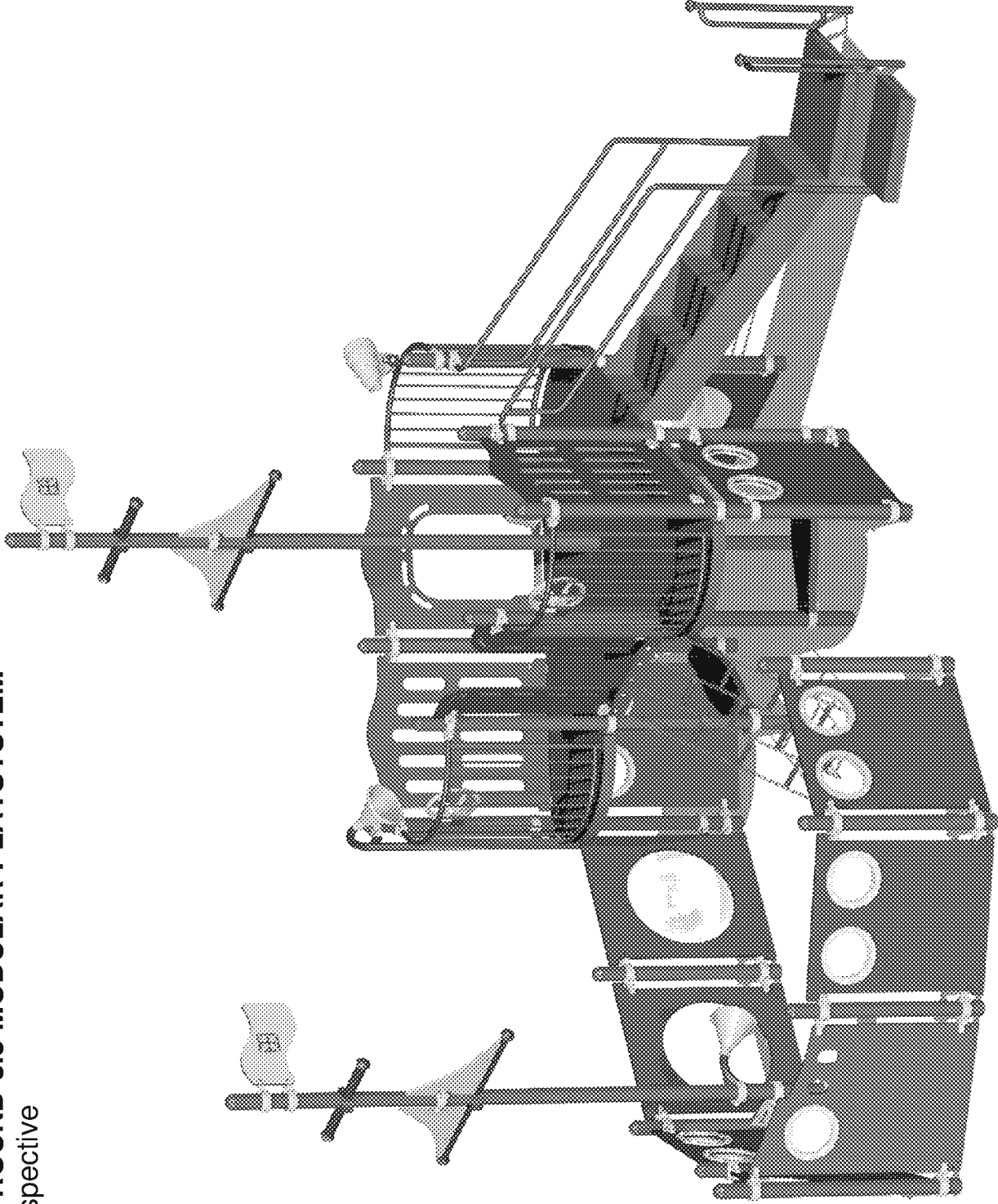

PR#: BFE18A
Date: 08/18/08
Drawn By: CMC

TEXAS SOUTHMOST COLLEGE
Creative Components



123 NORTH VALLEY DRIVE
GRANTS PASS, OR 97526
PH: 541-955-9199
FAX: 541-955-6130
www.playcraftsystems.com

CUSTOM ROUND 3.5 MODULAR PLAYSYSTEM

Back Perspective

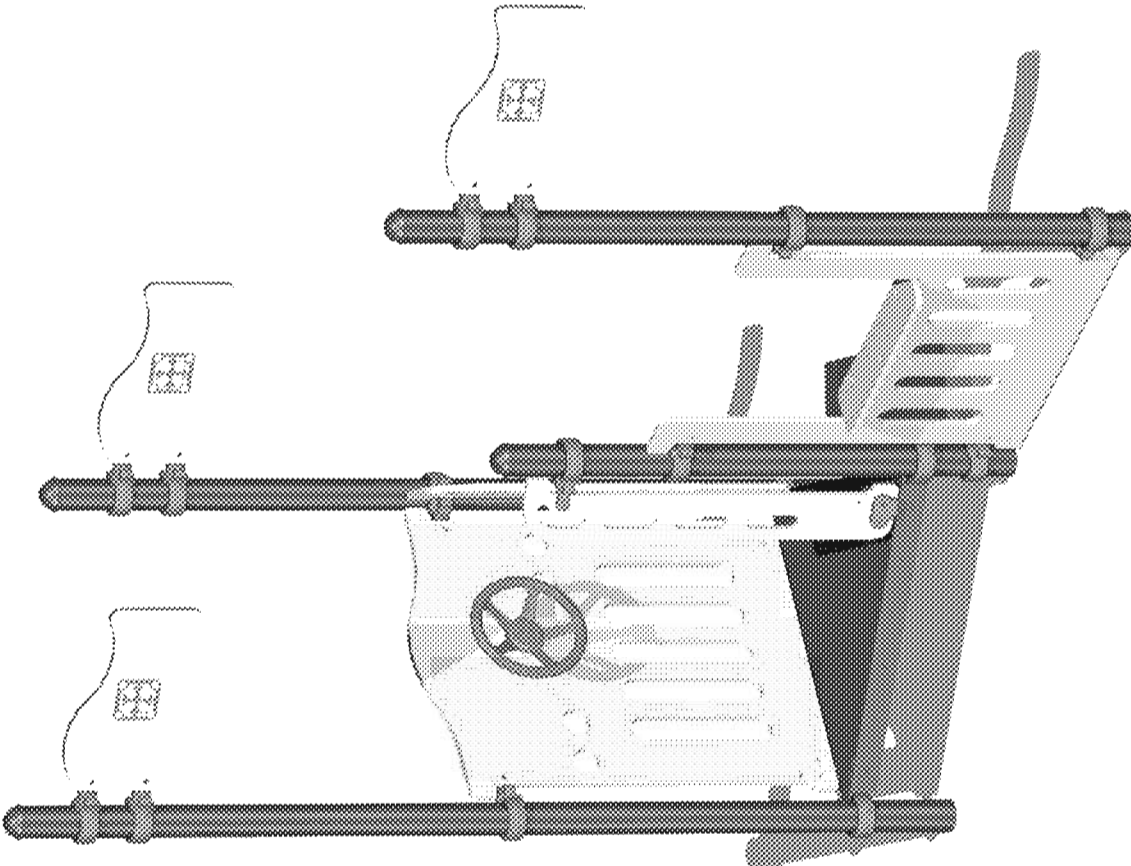

PR#: 6E357A
Date: 08/19/08
Drawn By: CMC

TEXAS SOUTHMOST COLLEGE
Creative Components



PLAYCRAFT
SYSTEMS

123 NORTH VALLEY DRIVE
GRANTS PASS, OR 97526
PH: 541-955-9199
FAX: 541-955-6130
www.playcraftsystems.com

SANDBOX

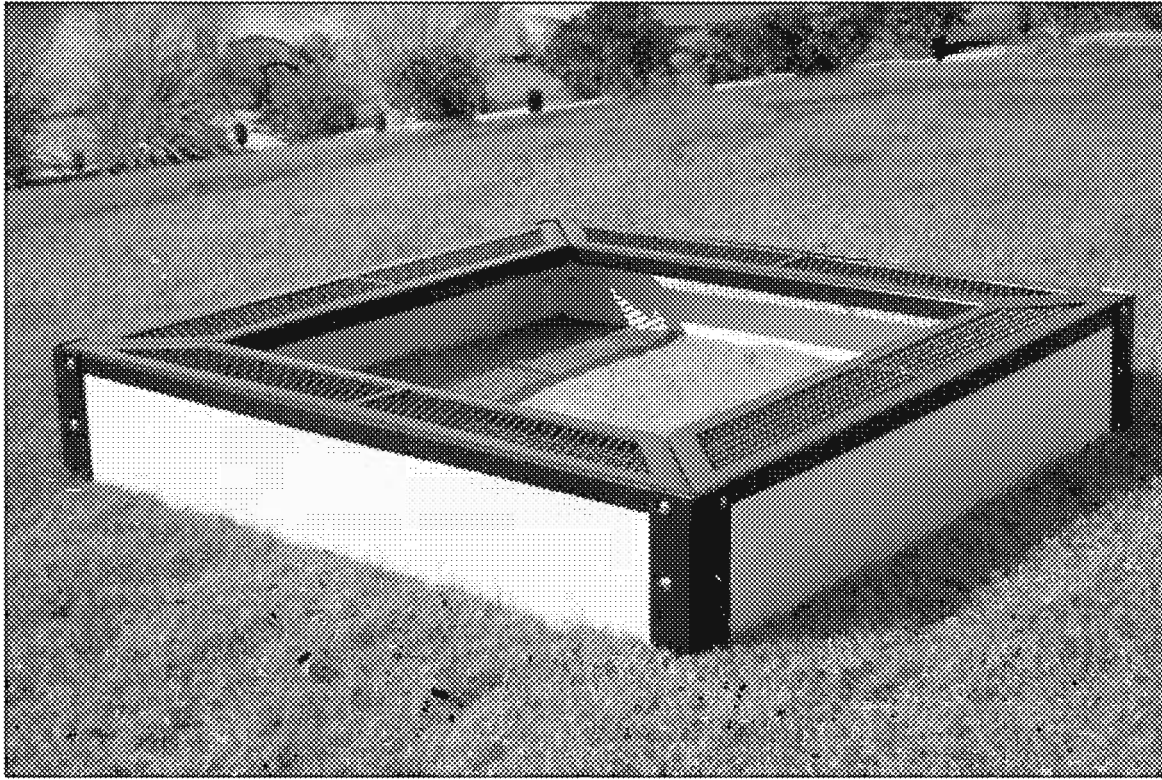

PAINT STATION



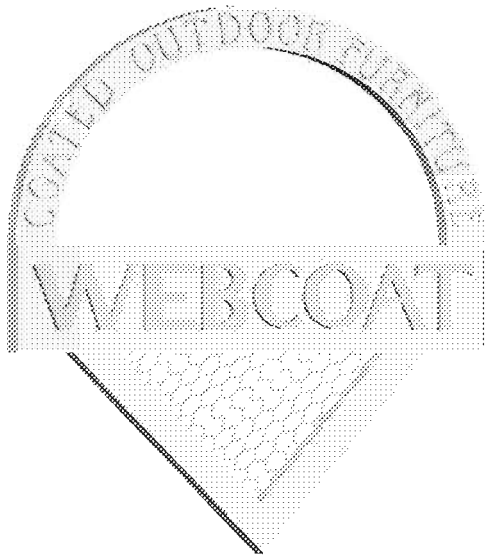

T6RC - ELEM

6' ROUNDED CORNER TABLE ELEMENTARY HEIGHT PORTABLE DESIGN

WEBCOAT PRODUCTS
P.O. BOX 3160
McALESTER, OKLAHOMA 74501
1-800-505-5101
FAX: (918)426-5924
E-MAIL: WEBCOAT@WEBCOAT.COM

Please take the time to locate and identify each part. Assemble the units on a smooth flat surface. It is also helpful to lay the tops and seats on cardboard or a drop cloth to prevent scratching of the surface during assembly. All parts have been pre-cut and pre-drilled for ease of assembly. All holes are slotted to allow for easy assembly and for final levelling of tops and seats to frames. Fully assemble all parts without totally tightening nuts and bolts. After all assembled go back and retighten nuts to bolts. DO NOT OVER TIGHTEN NUTS TO BOLTS. Over tightened nuts can crack the plastisol coating. All the necessary quantities of parts required are listed in this assembly instructions.

DO NOT BEGIN ASSEMBLY UNTIL YOU HAVE READ THESE INSTRUCTIONS AND ARE FAMILIAR WITH THE PARTS.

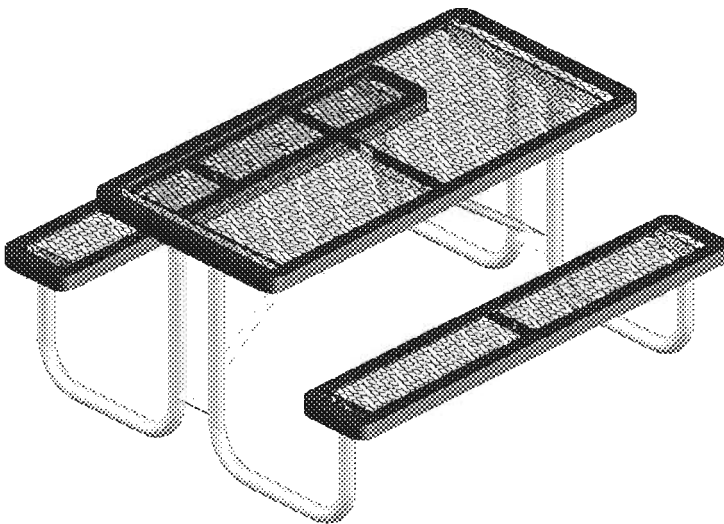

CUSTOM ROUND 3.5 MODULAR PLAYSYSTEM

Front Perspective

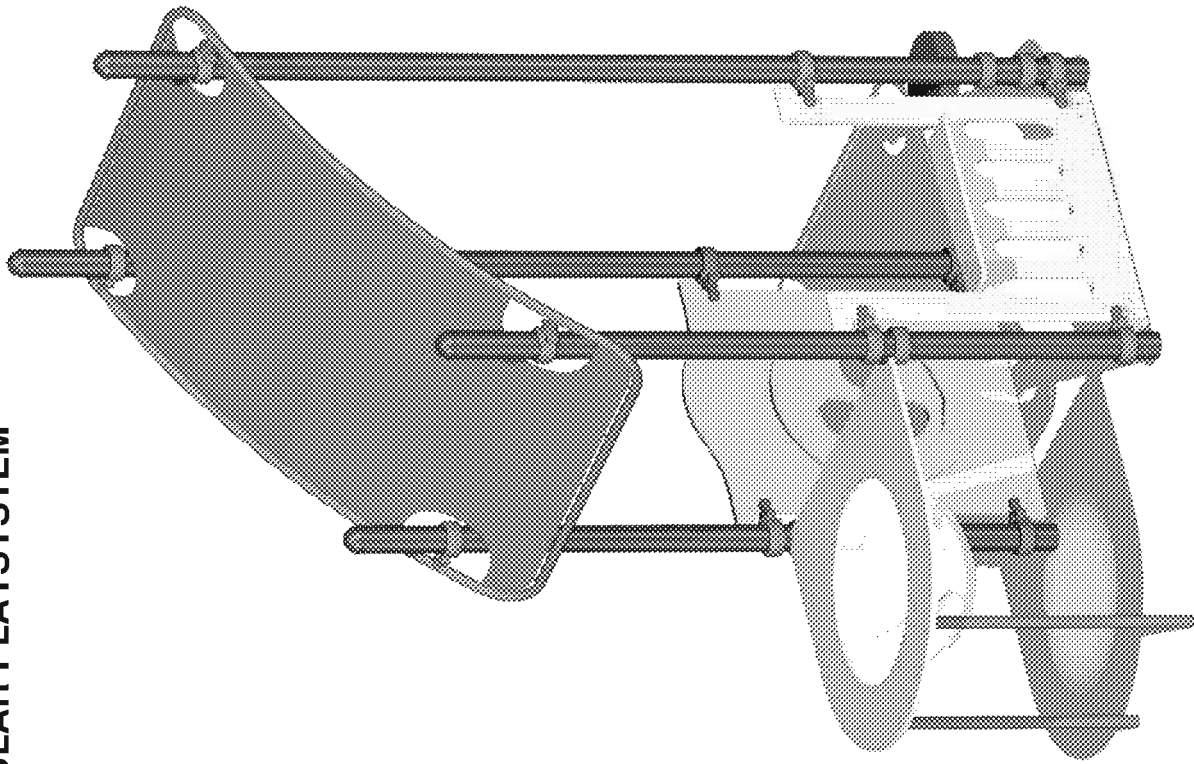

PR#: E5545A
Date: 08/19/08
Drawn By: CMC

TEXAS SOUTHMOST COLLEGE
Creative Components



123 NORTH VALLEY DRIVE
GRANTS PASS, OR 97526
PH: 541-955-9199
FAX: 541-955-6130
www.playcraftsystems.com

Cost Savings Calculations

Summary	RGV Contractor Credit	Owner Procured
Environmental Management System	\$74,050	\$63,550
Food Service Equipment	\$63,747	\$77,000
Playground Equipment	\$181,860	\$64,470
Total	\$319,657	\$205,020

TOTAL SAVINGS

\$114,637